



## 112 Series

### Ball Valves

#### Handle with Arrow

- indicates flow direction
- allows quick operation to open and close

#### Panel Mounting Nut

- allow easy installation

#### Variety of End Connections

- include fractional / metric Hy-Lok tube fittings, NPT female, ISO female threads.

#### Body Pattern

- is available in straight and angle.
- is available in 3-way and 4-way.

#### Orifice

- is optimized design for minimum pressure drop.

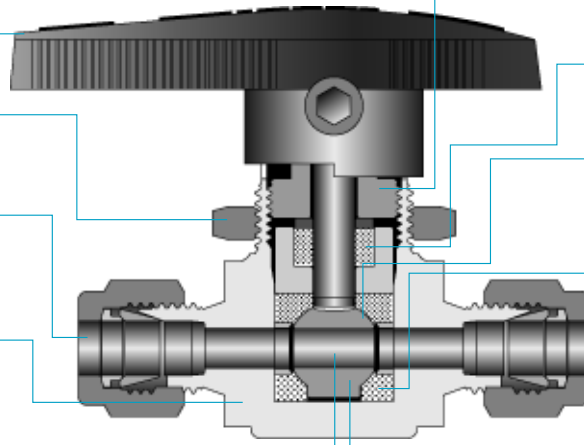

#### Packing Bolt

- allows easy packing adjustment with valve in-line.

#### PTFE Packing

- is supported by top and bottom glands.

#### Encapsulating Ball Seats

- virtually allow no dead volume
- are uniformly forced to form tight seals against ball and body cavity.

#### Metal Supports

- prevent cold flow of PTFE into orifice.

#### Integral Ball - Stem

- is machined from one piece.
- is best suited to encapsulate ball seats.

## Features

- **Pressure rating** up to 3000psig (206bar) at 70°F(21°C)
- **Temperature rating** from 50°F to 150°F (10°C to 65°C) with PTFE seat and packing
- **Vent to atmosphere available**
- **Both straight and angle, 3 - way and 4 - way patterns** available
- **Body materials** available in 316 stainless steel, brass, and alloy 400.
- **100% factory tested**

## Technical Data

### Materials of Construction

#### 2 - WAY & 3 - WAY

Description	Grade / ASTM Specification		
	Valve Body Materials		
	SS316	Brass	Alloy 400
Handle	Black Nylon		
Mounting Nut	Stainless Steel	Brass	Stainless Steel
Packing Bolt	TP316 / A479	Brass	TP316 / A479
Packing*	PTFE		
Packing Gland	316 Stainless Steel		
Encapsulating Ball Seats*	PTFE		
Supports*	Stainless Steel		
Ball Stem*	TP316 / A479		N04400 / B164
Body	TP316 / A479 or A182	Brass / B16	N04400 / B164

Note : "\*" marked are wetted parts. Lubricant is silicone based.

### Pressure Rating @ 50°F to 150°F(10°C to 65°C)

for the valve with standard seat and packing

Valve Designator	Straight 2 - way	Angle 2 - way	Switching 3 - way
B 1 V	2500 psig (172 bar)	2500 psig (172 bar)	2500 psig (172 bar)
B 2 V	3000 psig (206 bar)	2500 psig (172 bar)	2500 psig (172 bar)
B 3 V	2500 psig (172 bar)	1500 psig (103 Bar)	1500 psig (103 bar)
B 4 V	2500 psig (172 bar)	1500 psig (103 bar)	1500 psig (103 bar)



## 2-Way (Shut-Off Valve)

### Straight Pattern

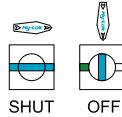
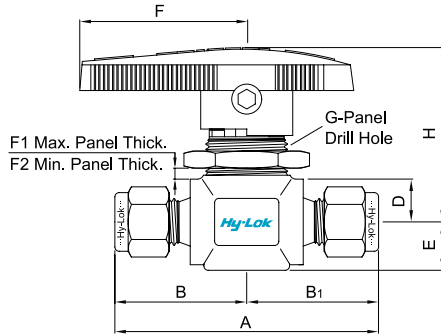

### Angle Pattern

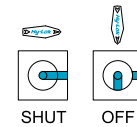
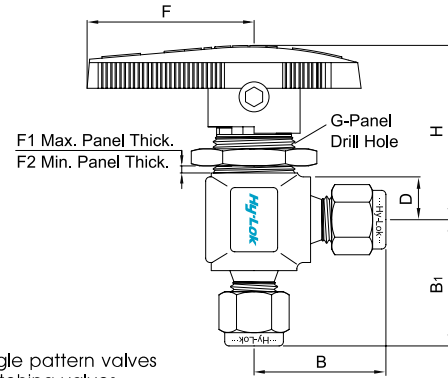

For the dimension B & B1 of angle pattern valves see the dimension of 3-way switching valves

### Table of Dimensions

Basic Part No.	Orifice		CV	End Connection	Dimensions (mm)																				
	mm	inch			Inlet & Outlet	A	B	B1	D	E	F	F1	F2	G	H	W									
B1VH - 1T	1.3	0.052	0.1	1/16 Hy-Lok	42.6	21.3	21.3	9.5	8.8	28.0	5.5	2.0	15.0	34.0	19.0										
B1VH - 3M	2.4	0.093	0.2	3mm Hy-Lok	50.8	25.4	25.4	9.5	8.8	28.0	5.5	2.0	15.0	34.0	19.0										
B1VH - 2T			0.2	1/8 Hy-Lok																					
B1VF - 2N	3.2	0.125	0.5	1/8 Female NPT	41.2	20.6	20.6	9.5	8.8	28.0	5.5	2.0	15.0	34.0	19.0										
B1VH - 6M			0.6	6mm Hy-Lok	55.4	27.7	27.7																		
B1VH - 4T			0.6	1/4 Hy-Lok																					
B2VF - 2N			1.2	1/8 Female NPT	50.8	25.4	25.4																		
B2VF - 4N	0.9	1/4 Female NPT	52.4	26.2	26.2	11.3	10.0	39.0	6.0	2.5	20.0	41.2	21.0												
B2VF - 4R	0.9	1/4 ISO Female Tapered																							
B2VM - 4N	1.2	1/4 Male NPT	50.8	25.4	25.4																				
B2VMH - 4N4T	1.6	1/4 Male NPT 1/4 Hy-Lok	55.6	25.4	25.4																				
B2VH - 6M	4.8	0.187	2.4	6mm Hy-Lok	60.4	30.2	30.2	11.3	10.0	39.0	6.0	2.5	20.0	41.2	21.0										
B2VH - 4T			2.4	1/4 Hy-Lok																					
B2VH - 8M			1.5	8mm Hy-Lok	62.0	31.0	31.0																		
B2VH - 6T			1.5	3/8 Hy-Lok	65.0	32.5	32.5																		
B3VF - 4N			7.1	0.281	3.0	1/4 Female NPT	63.6									31.8	31.8	17.5	14.3	51.0	9.0	3.0	28.0	52.8	33.0
B3VF - 6N					2.6	3/8 Female NPT																			
B3VF - 6R	2.6	3/8 ISO Female Tapered																							
B3VH - 6T	6.0	3/8 Hy-Lok			77.8	38.9	38.9																		
B3VH - 10M	6.0	10mm Hy-Lok																							
B4VF - 8N	10.3	0.406	6.3	1/2 Female NPT	79.2	39.6	39.6	22.0	17.5	77.0	10.0	3.0	39.0	67.0	41.0										
B4VF - 8R			6.3	1/2 ISO Female Tapered																					
B4VH - 12M			12.0	12mm Hy-Lok																					
B4VH - 8T			12.0	1/2 Hy-Lok	100.0	50.0	50.0																		
B4VH - 12T			6.4	3/4 Hy-Lok																					

All dimensions are in millimeters. Dimensions shown with Hy-Lok nuts in finger-tight position, where applicable

### Flow Rate

Pressure Drop to Atmosphere ( $\Delta p$ ) in psi	Cv															
	0.1	0.2	0.5	0.6	0.9	1.2	1.5	1.6	2.4	2.6	3.0	6.0	6.3	6.4	12.0	
Air SCFM @70°F(21°C)	10	1.1	2.7	6.9	8.3	12.0	17.0	21.0	22.0	33.0	36.0	41.5	83.0	87.2	88.6	166.0
	50	3.0	7.6	19.1	23.0	34.0	46.0	57.0	61.0	92.0	99.5	115.0	230.0	241.0	245.0	459.0
	100	5.3	14.0	33.9	40.7	61.0	81.0	100.0	110.0	160.0	176.0	203.0	407.0	427.0	434.0	814.0
Water US GPM @70°F(21°C)	10	0.3	0.6	1.6	1.9	2.8	3.7	4.7	5.0	7.5	8.2	9.5	19.0	19.9	20.2	37.9
	50	0.7	1.4	3.5	4.2	6.3	8.4	11.0	11.0	17.0	18.4	21.2	42.3	44.5	45.3	84.9
	100	1.0	2.0	5.0	6.0	9.0	12.0	15.0	16.0	24.0	26.0	30.0	60.0	63.0	64.0	120.0

The Cv is for the straight pattern valves. Cvs of angle pattern valves are the same as those of 3-way valves

### 3 - Way (Switching Valves)

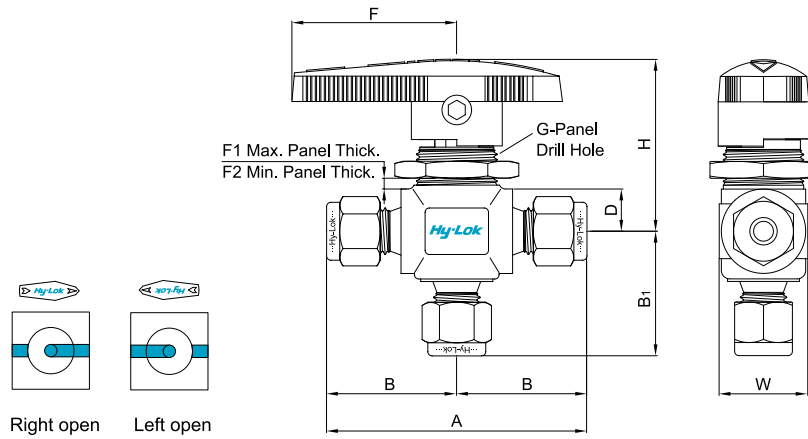

Table of Dimensions

Basic Part No.	Orifice		Cv	End Connection		Dimensions (mm)												
	mm	inch		Side port	Bottom port	A	B	B <sub>1</sub>	D	F	F <sub>1</sub>	F <sub>2</sub>	G	H	W			
B1V3H -1T	1.3	0.052	0.08	1/16 Hy-Lok		42.6	21.3	20.6	8.8	28.0	5.5	2.0	15.0	34.0	19.0			
B1V3H -3M	2.4	0.093	0.15	3mm Hy-Lok		50.8	25.4	24.6	8.8	28.0	5.5	2.0	15.0	34.0	19.0			
B1V3H -2T			0.15	1/8 Hy-Lok														
B1V3F -2N	3.2	0.125	0.30	1/8 Female NPT		41.2	20.6	20.6	8.8	28.0	5.5	2.0	15.0	34.0	19.0			
B1V3H -6M			0.35	6mm Hy-Lok		55.4	27.7	26.9										
B1V3H -4T			0.35	1/4 Hy-Lok														
B2V3F -4N			0.75	1/4 Female NPT		52.4	26.2	26.2										
B2V3F -4R	0.75	1/4 ISO Female Tapered																
B2V3H -6M	4.8	0.187	0.90	6mm Hy-Lok		60.4	30.2	29.5	10.0	39.0	6.0	2.5	20.0	41.2	21.0			
B2V3H -4T			0.90	1/4 Hy-Lok														
B2V3HM -4T4N			0.80	1/4 Hy-Lok	1/4 Male NPT											62.0	31.0	30.2
B2V3H -8M			0.80	8mm Hy-Lok														
B3V3F -4N	7.1	0.281	1.7	1/4 Female NPT		63.6	31.8	31.8	14.5	51.0	9.0	3.0	28.0	52.8	30.0			
B3V3F -6N			1.5	3/8 Female NPT														
B3V3F -6R			1.5	3/8 ISO Female Tapered														
B3V3H -6T			2.0	3/8 Hy-Lok		73.2	36.6	35.8										
B3V3H -10M			2.0	10mm Hy-Lok														
B4V3F -8N	10.3	0.406	3.5	1/2 Female NPT		79.2	39.6	39.6	17.5	77.0	10.0	3.0	39.0	67.0	41.0			
B4V3F -8R			3.5	1/2 ISO Female Tapered														
B4V3H -12M			4.6	12mm Hy-Lok		89.0	44.5	44.5										
B4V3H -8T			4.6	1/2 Hy-Lok														
B4V3H -12T			3.8	3/4 Hy-Lok														

All dimensions are in millimeters. Dimensions shown with Hy-Lok nuts in finger-tight position, where applicable

### Flow Rate

Pressure Drop to Atmosphere ( p ) in psi	Cv													
	0.08	0.15	0.30	0.35	0.75	0.8	0.9	1.5	1.7	2.0	3.5	3.8	4.6	
Air SCFM @70°F(21°C)	10	0.9	2.0	4.2	4.8	10.0	11.0	12.0	20.8	23.5	27.7	48.4	52.6	63.7
	50	2.4	5.7	11.5	13.4	29.0	31.0	34.0	57.4	65.0	76.5	134.0	145.0	176.0
	100	4.3	10.1	20.3	23.7	51.0	54.0	61.0	102.0	115.0	136.0	237.0	258.0	312.0
Water US GPM @70°F(21°C)	10	0.3	0.4	0.9	1.1	2.3	2.5	2.8	4.7	5.4	6.3	11.1	12.0	14.5
	50	0.6	1.0	2.1	2.5	5.3	5.6	6.3	10.6	12.0	14.1	24.7	26.9	32.5
	100	0.8	1.5	3.0	3.5	7.5	8.0	9.0	15.0	17.0	20.0	35.0	38.0	46.0

### Testing

- Each valve is tested with nitrogen @ 1000psig(69bar) to max leak rate of 0.1SCCM.
- Optional tests are available upon request.

### Sour Gas Service

- is provided to meet NACE Standard MR - 01 - 75.

### Packing Adjustment

- Valves are factory adjusted for 1000psig service at 70°F(21°C).
- For services at higher pressure, the packing must be readjusted. This can be done with the valve in - line. Untighten the hex key to remove the handle. Tighten the packing bolt clockwise with the increment of **a quarter of a quarter** turn (22.5°) until leaktight seal is obtained. And then reassemble.
- Exposure of valves to varying temperature can affect the initial packing load. You may need check leak and readjust packing bolt.

### For 3-way (Switching Valves)

**⚠ Attention**

- 1) Check the flow direction
- 2) Do not use quarter turn the handle for block (Only guarantee the 180° turn the handle)

## Ordering Information

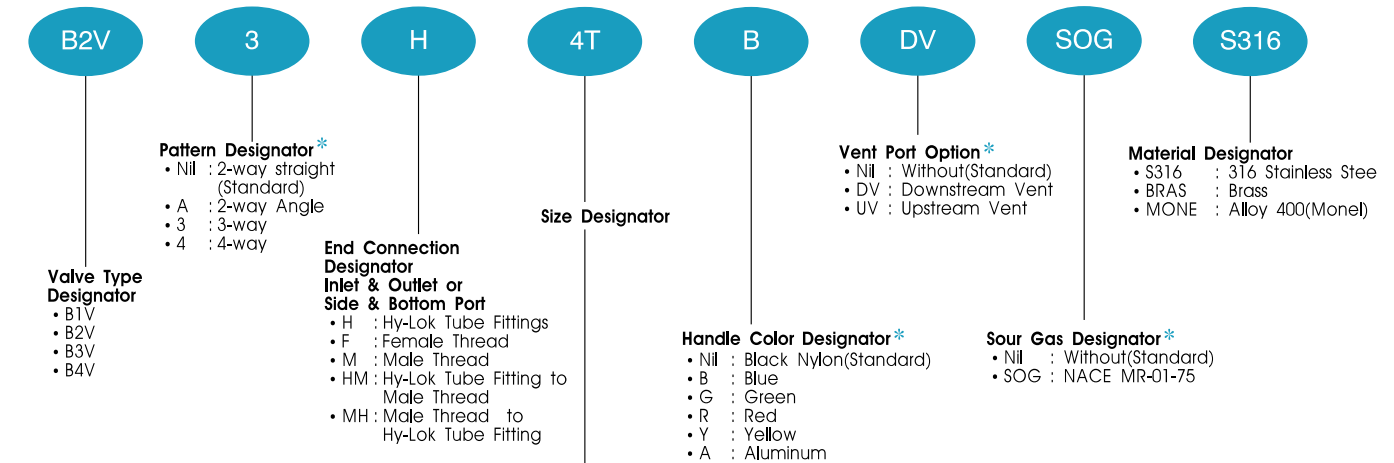

• NPT (ISO/BSP)

Thread(in)	1/8	1/4	3/8	1/2	3/4
Designator	2N(R)	4N(R)	6N(R)	8N(R)	12N(R)

• Tube

Fractional Tube	O.D(in.)	1/16	1/8	1/4	3/8	1/2	5/8	3/4
Designator		1T	2T	4T	6T	8T	10T	12T
Metric Tube	O.D(mm)	3	6	8	10	12	16	20
Designator		3M	6M	8M	10M	12M	16M	20M

**Note** \*: No designator is required for standard, black nylon handle, e.g.B2VH-4T-S316.

### SAFETY in VALVE SELECTION

Proper installation, materials compatibility, operation and maintenance of these valves are the responsibility of the user. The total system design must be taken into consideration to ensure optimal performance and safety.