

Hy-Lok BLF Series

Forged Bellows Valves

Catalog No. H-BL200
Apr, 2023



Design & Engineering

- Forged body bellows valves
- Maximum working pressure is up to 145 psig (10 bar)
- Temperature rating is up to 200°F (93°C)
- Tube & pipe butt weld, Hy-Lok tube fitting, and Flange ends
- 100% helium leak tested

Application

- Semiconductor
- Biotech
- Pharmaceutical

HY-LOK CORPORATION

©2006-2023 HY-LOK CORPORATION All rights reserved



ISO 14001



OHSAS 18001



Features

- Forged body reduced the total weight.
- Choice of Butt weld, Hy-Lok tube fitting and Flange Type.
- Easily Purged to maintain clean operation.
- Bottom mounting standard.
- 100% helium leak tested.

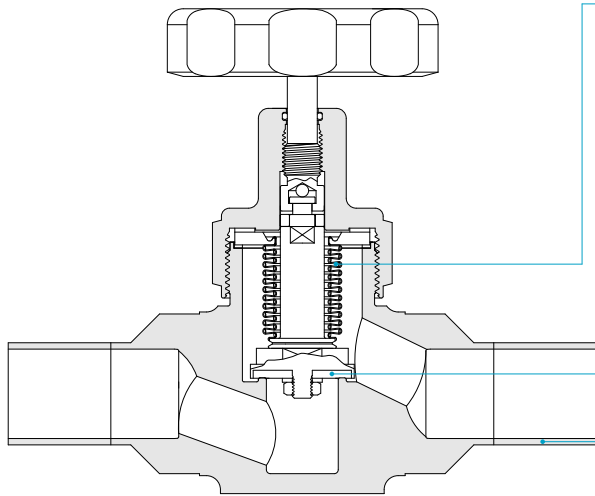

- Precision formed metal bellows for long cycle life.
- Replaceable subassembly for easy maintenance.
- PCTFE stem tip standard for leak-tight, repetitive shutoff.
- Nonrotating stem tip for long cycle life.
- Variable end connections
- Include butt welds, Hy-Lok tube fittings and flanges.

Materials

No.	Description	Material / ASTM Specification
1	Body	Single Vacuum Melt 316L / A479
2	Bellows	Type 321 / A269
3	Stem Tip	PCTFE
4	Gasket	PCTFE
5	Bonnet	Type 316 / A479
6	Handle	Aluminum

Specification

Series	Orifice in. (mm)	Cv	Pressure Rating psig (bar)	Temp. Rating °F (°C)
BLFV1	0.472(12.0)	2.6	Round Handle : 145 (10)	-20 ~ 200 (-28 ~ 93)
BLFV2	0.59(15.0)	2.9	Normally Open : 145 (10)	
BLFV3	0.787(20.0)	4.8	Normally Close : 125 (8.6)	

Internal Surface Grade

Grade	Designator	Roughness Average Ra. (E.P)	Packing Standard Class 10
B.A.	B	0.25 μm (10 μin)	Double
High	H	0.13 μm (5 μin)	

- Grade "B.A." is standard.

Cleaning & Testing

Passivation is done at Nitrogen environment. Fine cleaning is one by Ultrasonic cleansing with resistivity over 18MΩ D.I water after finishing the passivation. Inboard helium leak tested to a rate of 4 x 10⁻⁹cm³/s.

Assembly & Packaging

Assembly and Packaging is performed in the clean room of Class 10. Valves are packed with anti-static polyethylene bag that is pressured into the high purity nitrogen gas.

Dimensions

All Dimensions are in millimeters, except for the O.D size.

In case of the end connection for Hy-Lok tube fitting, dimensions shown with Hy-Lok nuts in finger-tight position, where applicable.

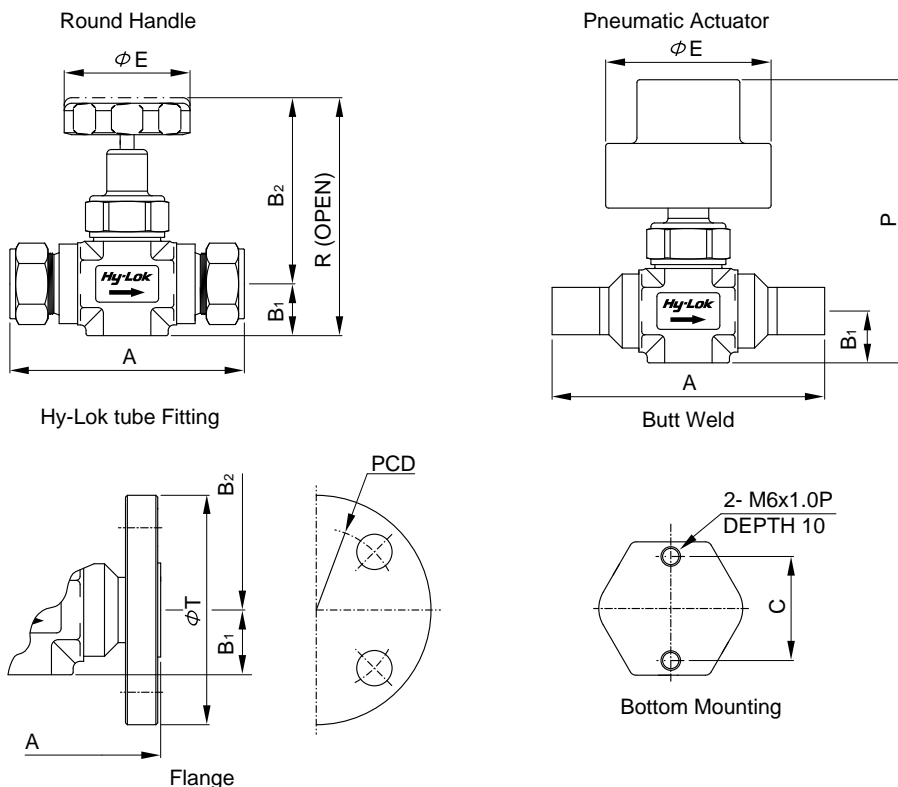

End Connection		Ordering No.	Orifice	A	B ₁	B ₂	C	D	E	P	R	T	PCD
Type	Size												
Hy-Lok Tube Fitting	3/4"	BLFV1H-12	12.0	100.2	24.0	99.0	30.0	60.0	60.0	160.0	123.0	-	-
	1"	BLFV2H-16	15.0	126.7	28.0	101.5	35.0	70.0	100.0	210.0	129.5	-	-
	1"	BLFV3H-16	20.0	154.8	33.0	124.5	40.0	80.0	100.0	220.0	157.5	-	-
	1 1/4"	BLFV3H-20	20.0	173.8	33.0	124.5	40.0	80.0	100.0	220.0	157.5	-	-
Pipe Butt Weld	1/2"	BLFV1BW-15A	12.0	190.0	24.0	99.0	30.0	60.0	60.0	160.0	123.0	-	-
	3/4"	BLFV2BW-20A	15.0	200.0	28.0	101.5	35.0	70.0	100.0	210.0	129.5	-	-
	1"	BLFV3BW-25A	20.0	210.0	33.0	124.5	40.0	80.0	100.0	220.0	157.5	-	-
* FLANGE	1/2"	BLFV1RF10K-15A	12.0	108.0	24.0	99.0	30.0	60.0	60.0	160.0	123.0	95.0	70.0
	3/4"	BLFV2RF10K-20A	15.0	117.0	28.0	101.5	35.0	70.0	100.0	210.0	129.5	100.0	75.0
	1"	BLFV3RF10K-25A	20.0	127.0	33.0	124.5	40.0	80.0	100.0	220.0	157.5	125.0	90.0

* JIS flange is standard. ANSI flange as an option. For the ordering number of the ANSI flange, refer to the ordering information (Page 4).

Maintenance Kits

Stem Tip Kits



Ordering number is the following.

Series	Orifice	Ordering No.
BLFV1	12.0mm	BLFV1STA-PCTFE
BLFV2	15.0mm	BLFV2STA-PCTFE

Bellows Welded Kits (Bellows, lower stem and weld ring)



Ordering number is the following.

Series	Orifice	Ordering No.
BLFV1	12.0mm	BLFV1-BELS
BLFV2	15.0mm	BLFV2-BELS
* BLFV3	20.0mm	BLFV3-BELS

* Kits include bellows, lower stem, weld ring and stem tip.

BL Series

Flow Data at 70°F (20°C)

Air & Water Flow Data

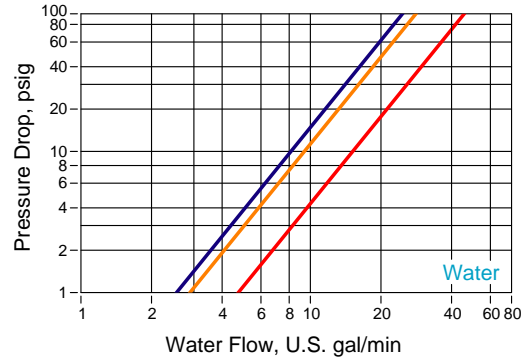
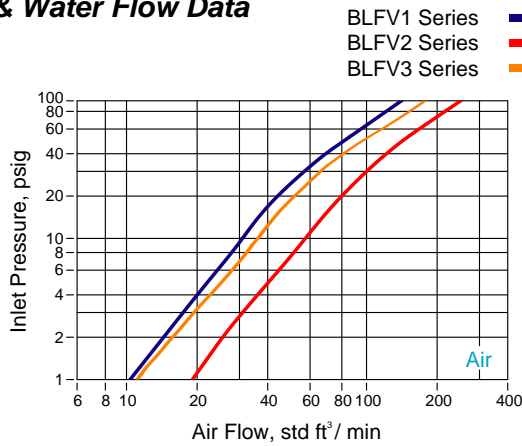

Round Handle Flow Coefficient at Turns Open

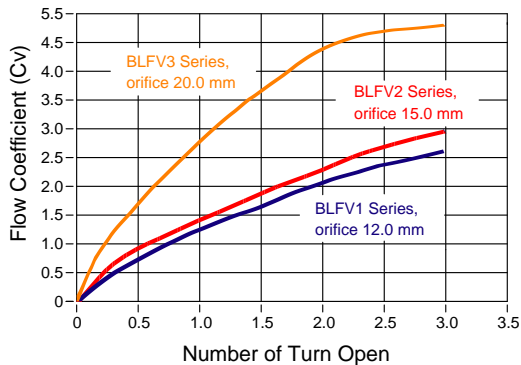

Pneumatic Actuator Performance

- BLFV1 Series — Normally Open — Normally Close
 BLFV2 Series — Normally Open — Normally Close
 BLFV3 Series — Normally Open — Normally Close

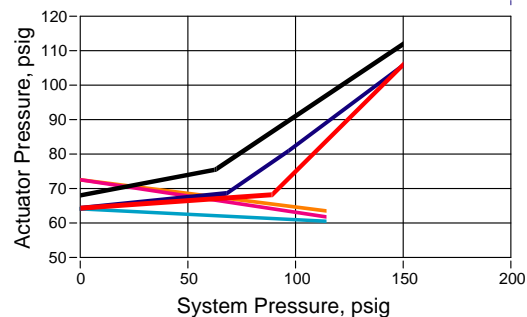

Ordering Information

BLFV2

Series Designator by Orifice Size

- BLFV1 - orifice 12.0 mm
- BLFV2 - orifice 15.0 mm
- BLFV3 - orifice 20.0 mm

BW

End Connection Designator

- H - Hy-Lok Tube Fitting
- BW - Butt Weld
- RF10K - JIS Flange RF 10kg/cm²
- RF150 - ANSI Flange RF 150 Class

16

Size Designator

PO

Pneumatic Actuator Designator

- Nil - Round Handle
- PO - Pneumatic Actuator (Normally Open)
- PC - Pneumatic Actuator (Normally Close)

H

Surface Grade Designator

- Nil - Grade "B.A"
- H - Grade "High"

SM6L

Body Material Designator

- SM6L - Single Vacuum Melt 316L ASTM A479

• Pipe Size

Nom. Pipe Size	1/2"	3/4"	1"
Designation	15A	20A	25A

• Tube Size

Tude O.D	3/4"	1"	1 1/4"
Designation	12	16	20

SAFETY in VALVE SELECTION

Proper installation, material compatibility, operation and maintenance of these valves are the responsibility of the user. The total system design must be taken into consideration to ensure optimal performance and safety.