

Cryogenic and High Temperature Valve

U.S. Type 859 (Includes Sub-CFL)

DESCRIPTION

The U.S. Type 859 globe control valve with cooling fin bonnet is used in extreme temperature applications. It is designed for modulating flow control in industrial applications at 400...700° F (204...371° C) at pressures less than 5000 psi (344 bar) (dependent on body and packing material). The added bonnet length and fins serve to reduce the heat at the packing area. This allows the standard CV ring packing to be used at higher process temperatures than could normally be tolerated with the standard valve.

APPLICATIONS

The Type 859 valve is widely used in high temperature applications where steam, hot water, hot hydraulic oil or other fluids or gases must be controlled precisely through 1/4 in. (6 mm), 1/2 in. (12 mm), 3/4 in. (19 mm) or 1 in. (25 mm) lines. Extended cooling fin valves are available for applications that exceed 700° F (371° C).

During the selection process, consult the appropriate pressure and temperature rating literature of the body and packing materials. This information is available in the catalog or from the factory.

MATERIALS

Body – Bonnet	
Standard	316 stainless steel, carbon steel (WCB)
Optional	Monel®, Alloy 20, Hastelloy® C and B or ASTM equivalent
Innervalue	
Standard	316 stainless steel
Optional	Stellite®, Monel, alloy 20, Hastelloy C and B or ASTM equivalent
Packing	
Standard	TFE chevron rings
Optional	Graphite
Actuator	
	Die cast aluminum
	316L stainless steel on standard 1/2 in. (12.7 mm) models

ACTUATOR OPTIONS

Standard	Air-to-open, fail close Air-to-close, fail open
Optional	With integral top mounted positioner
Standard Signals	3-15#, 3-27#, 6-30#
Optional Signals	3-9#, 9-15#, with positioner
Accessories	Filter regulator, gauges, I/P converter, limit switches, handwheel, solenoids



Shown with Type 754 Actuator

STANDARD FEATURES

- 1/4 in. (6 mm), 1/2 in. (12 mm), 3/4 in. (19 mm) and 1 in. (25 mm) models
- Interchangeable trim sets
- Cooling fin bonnet
- Trim characteristics: Linear, equal percent, quick open or double taper
- TFE chevron packing
- ANSI Class IV shutoff (size O and larger)
- High temperature rating

OPTIONAL FEATURES

- Butt and socket weld ends, BSPP, tube connection and others
- Bellows packing solutions
- Angle pattern body
- Reduced Emissions Kalrez® (REK), graphite, spring-loaded chevron and others
- Exotic alloys for complete valves or trims
- Stellite trims & soft seats (PTFE & Kel-F)
- TiN coating of innervalue stem and seat

PRESSURE VS TEMPERATURE RATINGS FOR VALVE SUPERSTRUCTURE

The pressure/temperature ratings listed here are based on material cross sections at the joint between the body and bonnet where a gasketed screw type bonnet is used. When the proper torque levels are used, the valve should not experience rupture of the joint or the material. The listed torque levels were used in hydrostatic tests at the factory at 70° F (21.1° C) at maximum body rating and were found to provide acceptable seating. Other factors, such as high or cyclic temperatures, light process gases, or poor gasket surfaces can dictate the ability of a seal to be made. Under such conditions, the only way to be sure of tight sealing is to perform a test under the actual process conditions.

These charts are not intended as an indication of functionality or suitability for control service. Other charts are available to assist in the choosing of valve type, bonnet type, trim type and actuator.

When flanges, fittings or other pressure containing elements are added to the valve, the pressure rating of the total valve assumes the rating of the weakest component.

The following charts exclude packing or end fittings:

1/4 in. Research Control Valve						
Temp	316 S/S psi (bar)	Carbon Steel psi (bar)	Hastelloy B or = psi (bar)	Hastelloy C or = psi (bar)	Monel psi (bar)	Alloy 20 psi (bar)
100° F (37.8° C)	5000 (345)	4000 (276)	5000 (345)	5000 (345)	4000 (276)	5000 (345)
200° F (93.3° C)	5000 (345)	3700 (255)	5000 (345)	5000 (345)	4000 (276)	5000 (345)
300° F (148.9° C)	4750 (328)	3500 (241)	5000 (345)	5000 (345)	3880 (268)	4850 (334)
400° F (204.4° C)	4190 (289)	3200 (221)	5000 (345)	5000 (345)	3770 (260)	4700 (324)
500° F (260.0° C)	4000 (276)	2900 (200)	4900 (338)	4900 (338)	3740 (258)	4500 (310)
600° F (315.6° C)	3820 (263)	2600 (179)	4850 (334)	4850 (334)	3740 (258)	4200 (290)
700° F (371.1° C)	3640 (351)	2300 (159)	4800 (331)	4800 (331)	3640 (251)	3900 (269)
800° F (426.7° C)	3580 (247)	—	4750 (328)	4750 (328)	3580 (247)	3700 (255)
900° F (482.2° C)	2840 (196)	—	—	4500 (310)	2280 (157)	3000 (207)
1000° F (537.8° C)	1160 (80)	—	—	4000 (276)	940 (65)	1500 (103)
1100° F (593.3° C)	Consult factory for higher temperatures.			3500 (241)	—	—
1200° F (648.9° C)	Consult factory for higher temperatures.			3000 (207)	—	—
Recommended torque in ft-lb (Nm), +/- 2 ft-lb (2.71 Nm)						
	37 (50)	37 (50)	39 (53)	37 (50)	31 (42)	35 (47)

1/2 in. Research Control Valve						
Temp	316 S/S psi (bar)	Carbon Steel psi (bar)	Hastelloy B or = psi (bar)	Hastelloy C or = psi (bar)	Monel psi (bar)	Alloy 20 psi (bar)
100° F (37.8° C)	5000 (345)	4000 (276)	5000 (345)	5000 (345)	4000 (276)	5000 (345)
200° F (93.3° C)	4750 (328)	3800 (262)	5000 (345)	5000 (345)	3780 (261)	5000 (345)
300° F (148.9° C)	4310 (297)	3600 (248)	5000 (345)	5000 (345)	3520 (243)	4950 (341)
400° F (204.4° C)	3860 (266)	3300 (228)	5000 (345)	5000 (345)	3420 (236)	4850 (334)
500° F (260.0° C)	3640 (251)	3100 (214)	4900 (338)	4900 (338)	3390 (234)	4600 (317)
600° F (315.6° C)	3470 (239)	2900 (200)	4850 (334)	4870 (336)	3390 (234)	4300 (296)
700° F (371.1° C)	3310 (228)	2700 (186)	4800 (331)	4610 (318)	3310 (228)	4200 (290)
800° F (426.7° C)	3255 (224)	—	4750 (328)	4430 (305)	2090 (114)	4000 (276)
900° F (482.2° C)	3190 (220)	—	—	4200 (290)	2070 (143)	3000 (207)
1000° F (537.8° C)	1860 (128)	—	—	4000 (276)	850 (59)	1500 (103)
1100° F (593.3° C)	Consult factory for higher temperatures.			3400 (234)	—	—
1200° F (648.9° C)	Consult factory for higher temperatures.			3000 (207)	—	—
Recommended torque in ft-lb (Nm), +/- 2 ft-lb (2.71 Nm)						
	122 (165)	122 (165)	131 (178)	124 (168)	102 (138)	117 (159)

3/4 in. and 1 in. Research Control Valve				
Temp	316 S/S psi (bar)		Carbon Steel psi (bar)	
	3/4 in. (19.1 mm)	1 in. (25.4 mm)	3/4 in. (19.1 mm)	1 in. (25.4 mm)
100° F (37.8° C)	1500 (103)	1500 (103)	1500 (103)	1500 (103)
200° F (93.3° C)	1450 (100)	1450 (100)	1350 (93)	1350 (93)
300° F (148.9° C)	1325 (91)	1325 (91)	1325 (91)	1325 (91)
400° F (204.4° C)	1175 (81)	1175 (81)	1275 (88)	1275 (88)
500° F (260.0° C)	1100 (76)	1100 (76)	1200 (83)	1200 (83)
600° F (315.6° C)	1050 (72)	675 (46)	1100 (76)	1100 (76)
700° F (371.1° C)	840 (58)	250 (17)	1075 (74)	1075 (74)
800° F (426.7° C)	575 (40)	—	—	—
3/4 in. and 1 in. Torque = 290 ft-lb (393 Nm)				

DIMENSIONS

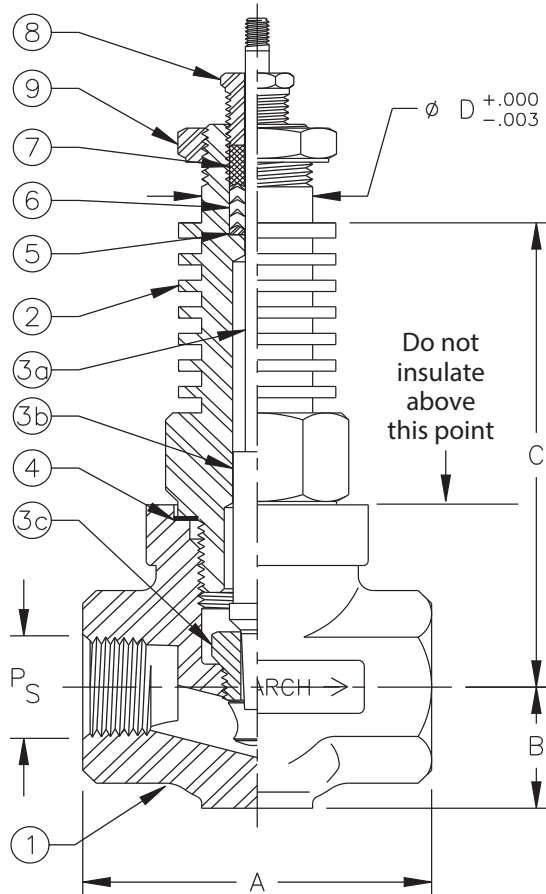

1. Valve body (investment cast, NPT ends)
2. Valve bonnet:
 1/4 in. (6.4 mm) = 7/8 in. (22.2 mm) hex;
 1/2 in. (12.7 mm) = 1-1/4 in. (31.8 mm) hex;
 3/4 in. (19.1 mm) = 1-1/2 in. (38.1 mm) hex;
 1 in. (25.4 mm) = 1-3/4 in. (44.5 mm) hex. (Some exotic materials may use round material.)
3. Innerset (trim set)
 - a. Plug
 - b. Stem: 1/4 in. (6.4 mm) = 1/8 in. (3.2 mm) \varnothing ;
 1/2 in. (12.7 mm) = 3/16 in. (4.8 mm) \varnothing ;
 3/4 in. (19.1 mm) = 3/16 (4.8 mm) \varnothing ;
 1 in. (25.4 mm) = 3/16 (4.8 mm) \varnothing
 - c. Seat: 1/4 in. (6.4 mm) = 3/8 in. (9.5 mm) hex;
 1/2 in. (12.7 mm) = 5/8 in. (15.9 mm) hex;
 3/4 in. (19.1 mm) = 3/4 in. (19.1 mm) hex ;
 1 in. (25.4 mm) = 15/16 in. (23.8 mm) hex
4. Body Bonnet Gasket (may not be supplied in exotic material)
5. Packing Adaptor (CV ring packing only)
6. Packing (CV ring)
7. Packing Follower (CV ring packing only)
8. Packing Gland: 1/4 in. (6.4 mm) = 7/16 in. (11.1 mm) hex;
 1/2 in. (12.7 mm) = 1/2 in. (12.7 mm) hex;
 3/4 in. (19.1 mm) = 1/2 in. (12.7 mm) hex;
 1 in. (25.4 mm) = 1/2 in. (12.7 mm) hex
9. Yoke Lock Nut: 1/4 in. (6.4 mm) = 7/8 in. (22.2 mm) hex;
 1/2 in. (12.7 mm) = 1-1/8 in. (28.8 mm) hex;
 3/4 in. (19.1 mm) = 1-1/8 in. (28.8 mm) hex;
 1 in. (25.4 mm) = 1-1/8 in. (28.8 mm) hex
10. Stem connector: 1/4 in. (6.4 mm) = 1/4 in. (6.4 mm) hex;
 1/2 in. (12.7 mm) = 3/8 in. (9.5 mm) hex;
 3/4 in. (19.1 mm) = 3/8 in. (9.5 mm) hex;
 1 in. (25.4 mm) = 3/8 in. (9.5 mm) hex
11. Upper Stem

PS	A	B	C	D	Stroke
3/4 in. (6.4 mm)	2.12 in. (53.8 mm)	0.68 in. (17.3 mm)	2.56 in. (65.0 mm)	0.625 in. (15.9 mm)	0.437 in. (11.1 mm)
1/2 in. (12.7 mm)	2.75 in. (69.8 mm)	1.00 in. (25.4 mm)	3.83 in. (97.3 mm)	0.875 in. (22.2 mm)	0.562 in. (14.3 mm)
3/4 in. (19.1 mm)	3.37 in. (85.6 mm)	1.18 in. (30.0 mm)	3.90 in. (99.1 mm)		
1 in. (25.4 mm)	4.00 in. (101.6 mm)	1.50 in. (38.1 mm)	3.95 in. (100.3 mm)		

INNERVALVE CHART

Valve Size	Trim Designation	Nominal Cv	Theoretical Turbulent Cv	Orifice Dia.	Orifice Area	Nominal Rangeability Linear	Equal %
1 in. (25.4 mm)	6.0	6.0	6.0	0.6250 (15.9 mm)	0.3068 in. ² (197.9 mm ²)	50:1	60:1
	5.0	5.0	5.0	0.6250 (15.9 mm)	0.3068 in. ² (197.9 mm ²)	50:1	60:1
	4.5	4.5	4.5	0.5000 (12.7 mm)	0.1963 in. ² (126.6 mm ²)	50:1	60:1
3/4 in. (19.1 mm) and 1 in. (25.4 mm)	4.0	4.0	4.0	0.5000 (12.7 mm)	0.1963 in. ² (126.6 mm ²)	50:1	60:1
	3.5	3.5	3.5	0.5000 (12.7 mm)	0.1963 in. ² (126.6 mm ²)	50:1	60:1
1/2 in. (12.7 mm), 3/4 in. (19.1 mm) and 1 in. (25.4 mm)	A	2.5	2.5	0.3750 (9.5 mm)	0.1104 in. ² (71.2 mm ²)	40:1	50:1
	B	2.0	2.0	0.3750 (9.5 mm)	0.1104 in. ² (71.2 mm ²)	40:1	50:1
	C	1.25	1.25	0.2810 (7.1 mm)	0.0620 in. ² (40.0 mm ²)	40:1	50:1
	D	0.8	0.8	0.2500 (6.4 mm)	0.0491 in. ² (31.7 mm ²)	40:1	50:1
	E	0.5	0.5	0.2500 (6.4 mm)	0.0491 in. ² (31.7 mm ²)	40:1	50:1
1/4 in. (6.4 mm), 1/2 in. (12.7 mm), 3/4 in. (19.1 mm) and 1 in. (25.4 mm)	F	0.32	0.32	0.1560 (3.9 mm)	0.0191 in. ² (12.3 mm ²)	30:1	40:1
	G	0.2	0.2	0.1560 (3.9 mm)	0.0191 in. ² (12.3 mm ²)	30:1	40:1
	H	0.13	0.13	0.1560 (3.9 mm)	0.0191 in. ² (12.3 mm ²)	30:1	40:1
	I	0.08	0.08	0.1560 (3.9 mm)	0.0191 in. ² (12.3 mm ²)	30:1	40:1
	J	0.05	0.05	0.1560 (3.9 mm)	0.0191 in. ² (12.3 mm ²)	30:1	40:1
	K	0.03	4.8E-02	0.0860 (2.2 mm)	0.0058 in. ² (3.7 mm ²)	25:1	—
	L	0.02	3.4E-02	0.0860 (2.2 mm)	0.0058 in. ² (3.7 mm ²)	25:1	—
	M	0.01	1.6E-02	0.0860 (2.2 mm)	0.0058 in. ² (3.7 mm ²)	25:1	—
	N	0.006	1.0E-02	0.0860 (2.2 mm)	0.0058 in. ² (3.7 mm ²)	25:1	—
	O	0.003	5.3E-03	0.0860 (2.2 mm)	0.0058 in. ² (3.7 mm ²)	25:1	—
1/4 in. (6.4 mm) and 1/2 in. (12.7 mm)	P1	0.002	3.6E-03	0.0625 (1.6 mm)	0.0031 in. ² (2.0 mm ²)	15:1	—
	P2	0.0013	2.5E-03	0.0625 (1.6 mm)	0.0031 in. ² (2.0 mm ²)	15:1	—
	P3	0.001	2.0E-03	0.0625 (1.6 mm)	0.0031 in. ² (2.0 mm ²)	15:1	—
	P4	0.0006	1.4E-03	0.0625 (1.6 mm)	0.0031 in. ² (2.0 mm ²)	15:1	—
	P5	0.0004	1.0E-03	0.0625 (1.6 mm)	0.0031 in. ² (2.0 mm ²)	15:1	—
	P6	0.00027	8.3E-04	0.0625 (1.6 mm)	0.0031 in. ² (2.0 mm ²)	15:1	—
	P7	0.00018	6.8E-04	0.0625 (1.6 mm)	0.0031 in. ² (2.0 mm ²)	15:1	—
	P8	0.00012	5.6E-04	0.0625 (1.6 mm)	0.0031 in. ² (2.0 mm ²)	15:1	—
	P9	0.00008	4.6E-04	0.0625 (1.6 mm)	0.0031 in. ² (2.0 mm ²)	15:1	—
1/4 in. (6.4 mm)	P10	0.00005	1.9E-04	0.0420 (1.1 mm)	0.0014 in. ² (0.9 mm ²)	15:1	—
	P11	0.000036	1.6E-04	0.0420 (1.1 mm)	0.0014 in. ² (0.9 mm ²)	15:1	—
	P12	0.000024	1.3E-04	0.0420 (1.1 mm)	0.0014 in. ² (0.9 mm ²)	15:1	—
	P13	0.000016	1.1E-04	0.0420 (1.1 mm)	0.0014 in. ² (0.9 mm ²)	15:1	—
	P14	0.00001	8.4E-05	0.0420 (1.1 mm)	0.0014 in. ² (0.9 mm ²)	15:1	—
	P15	0.000006	6.6E-05	0.0420 (1.1 mm)	0.0014 in. ² (0.9 mm ²)	15:1	—
	P16	0.000004	5.3E-05	0.0420 (1.1 mm)	0.0014 in. ² (0.9 mm ²)	15:1	—
	P17	0.0000027	4.4E-05	0.0420 (1.1 mm)	0.0014 in. ² (0.9 mm ²)	15:1	—
	P18	0.0000018	3.6E-05	0.0420 (1.1 mm)	0.0014 in. ² (0.9 mm ²)	15:1	—

K...O and the P series trims are considered reduced trims when installed in a 1/2 in. (12.7 mm) valve. Occasionally, P1...P9 trims are made on a 0.042 in. (1.1 mm) orifice.

PACKING/MEDIA TEMPERATURE

IMPORTANT

To prevent the stem from freezing, avoid packing temperatures below 0° C (32° F).

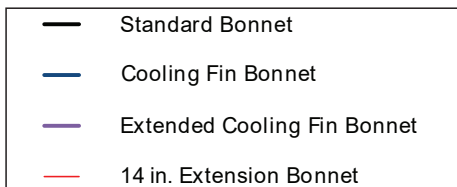
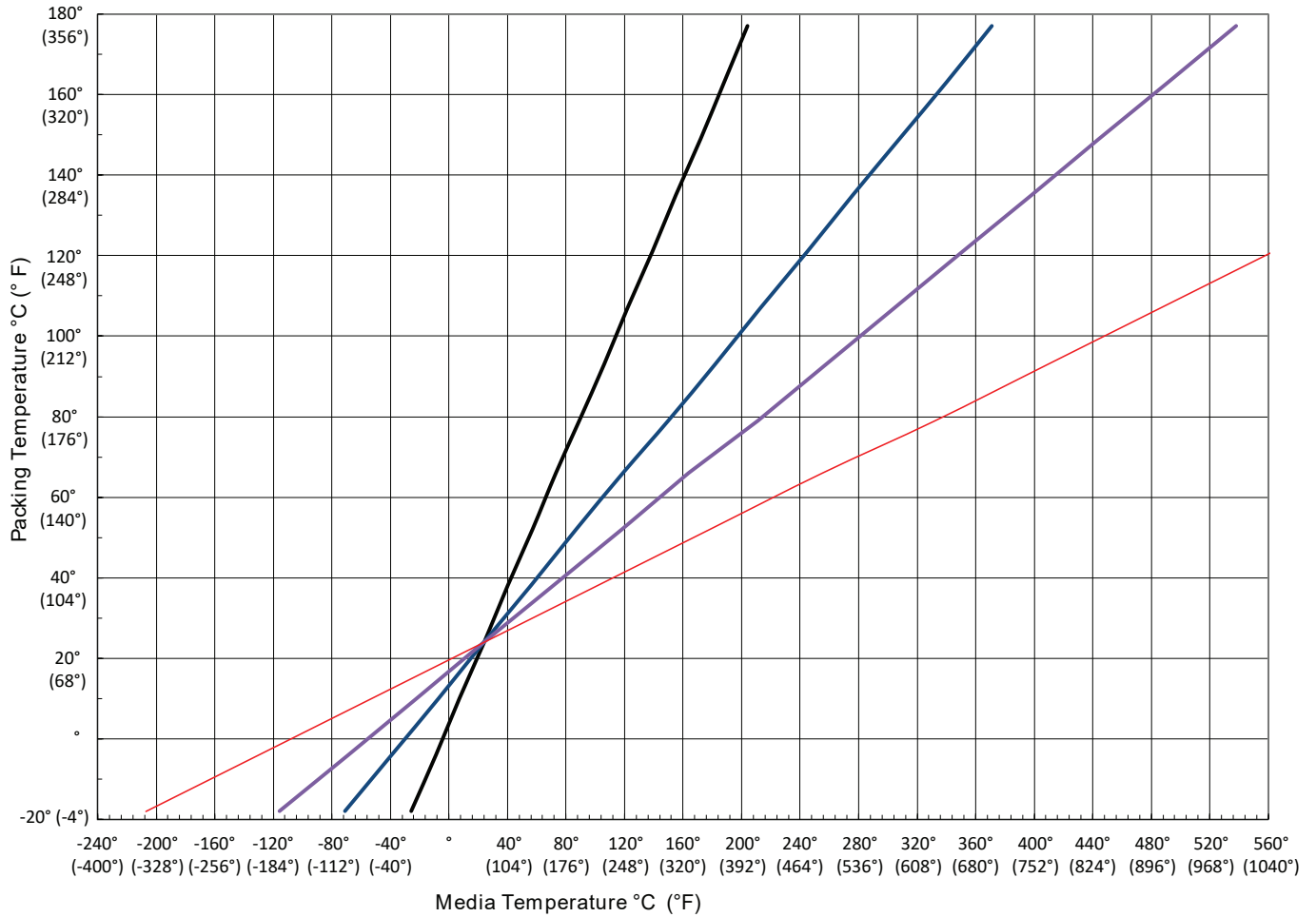

DESCRIPTION

The Type NRMA Non-Rotating Manual Actuation design is used in applications where either our low-flow trims, cooling fins or bellows are needed and when applications demand human interaction. The manual actuator can be mounted on all RC series valves, Including all "P" Trims and all Bonnets. Exchanging between electrical, pneumatic and manual actuators is therefore possible at any time with simple additions. The actuator is encapsulated and completely maintenance-free—designed for fine control.

APPLICATIONS

When you turn the hand wheel, the valve interior moves in a linear motion. This linear movement, from the hand wheel to the internal coupling, prevents damage to the trim and seat, distinguishing this design from conventional manual control valves.

FEATURES

- Hand drive, linear
- Suitable for Badger Meter® modular construction

MATERIALS

Case	1.4404 (316L)
Yoke	1.4404 (316L)
Hand Wheel	Duroplast

SPECIFICATIONS

Weight	Approximately 3.3 lb (1.5 kg)
Temperature	-40...176° F (-40...80° C)
Valve Lift	0.04 in. (1 mm) / 360° turn

SIZES FOR RESEARCH CONTROL VALVES

Sizes	Ø Average	Stroke
1/4 in. standard	0.625 in.	11.1 mm
1/2 in., 3/4 in., 1 in. standard	0.875 in.	14.3 mm
1/2 in., 3/4 in., 1 in. heavy duty guiding	0.875 in.	14.3 mm



DIMENSIONS

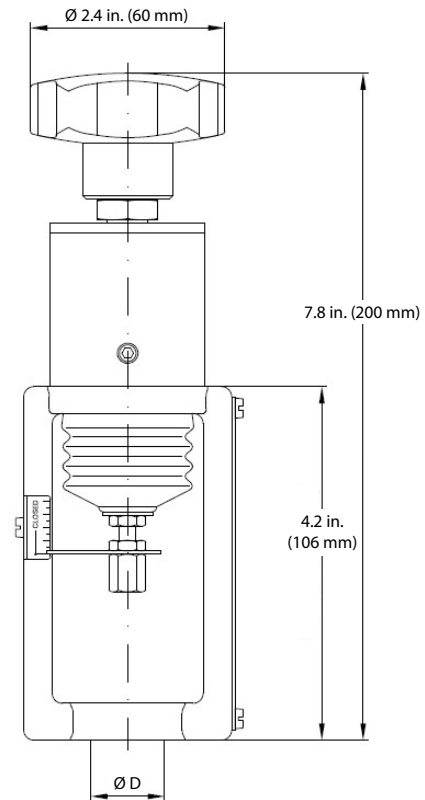

RCV Valves		Trim Sizes Equal %															
% Lift	% Cv	6.0	5	4.5	4	3.5	A	B	C	D	E	F	G	H	I	J	% Lift
0%	0%	0	0	0	0	0	0	0	0	0	0	0	0	0	0	0	0%
5%	1.0%	0.06	0.05	0.04	0.04	0.03	0.02	0.02	0.01	0.008	0.005	0.003	0.002	0.001	0.001	0.000	5%
10%	1.9%	0.11	0.10	0.09	0.08	0.07	0.05	0.04	0.02	0.015	0.010	0.006	0.004	0.002	0.002	0.001	10%
20%	3.8%	0.23	0.19	0.17	0.15	0.13	0.10	0.08	0.05	0.031	0.019	0.012	0.008	0.005	0.003	0.002	20%
25%	4.8%	0.29	0.24	0.22	0.19	0.17	0.12	0.10	0.06	0.038	0.024	0.015	0.010	0.006	0.004	0.002	25%
30%	5.9%	0.35	0.29	0.26	0.23	0.20	0.15	0.12	0.07	0.047	0.029	0.019	0.012	0.008	0.005	0.003	30%
40%	8.8%	0.53	0.44	0.40	0.35	0.31	0.22	0.18	0.11	0.070	0.044	0.028	0.018	0.011	0.007	0.004	40%
50%	13.2%	0.79	0.66	0.59	0.53	0.46	0.33	0.26	0.16	0.105	0.066	0.042	0.026	0.017	0.011	0.007	50%
60%	19.8%	1.19	0.99	0.89	0.79	0.69	0.49	0.40	0.25	0.158	0.099	0.063	0.040	0.026	0.016	0.010	60%
70%	29.6%	1.78	1.48	1.33	1.19	1.04	0.74	0.59	0.37	0.237	0.148	0.095	0.059	0.039	0.024	0.015	70%
75%	36.3%	2.18	1.81	1.63	1.45	1.27	0.91	0.73	0.45	0.290	0.181	0.116	0.073	0.047	0.029	0.018	75%
80%	44.4%	2.67	2.22	2.00	1.78	1.56	1.11	0.89	0.56	0.356	0.222	0.142	0.089	0.058	0.036	0.022	80%
90%	66.7%	4.00	3.33	3.00	2.67	2.33	1.67	1.33	0.83	0.533	0.333	0.213	0.133	0.087	0.053	0.033	90%
100%	100%	6.00	5.00	4.50	4.00	3.50	2.50	2.00	1.25	0.800	0.500	0.320	0.200	0.130	0.080	0.050	100%
Valve Sizes		1"	1"	1"	1", 3/4"	1", 3/4"	1-1/2"	1-1/2"	1-1/2"	1-1/2"	1-1/2"	1-1/4"	1-1/4"	1-1/4"	1-1/4"	1-1/4"	

Trim Sizes O through P-18 are available only in linear characteristic. See Product Data Sheets for maximum Cvs.

RCV Valves		Trim Sizes Equal %															
% Lift	% Cv	6.0	5	4.5	4	3.5	A	B	C	D	E	F	G	H	I	J	% Lift
0%	0%	0	0	0	0	0	0	0	0	0	0	0	0	0	0	0	0%
5%	1.0%	0.30	0.25	0.23	0.20	0.18	0.13	0.10	0.06	0.040	0.025	0.016	0.010	0.007	0.004	0.003	5%
10%	1.9%	0.60	0.50	0.45	0.40	0.35	0.25	0.20	0.13	0.080	0.050	0.032	0.020	0.013	0.008	0.005	10%
20%	3.8%	1.20	1.00	0.90	0.80	0.70	0.50	0.40	0.25	0.160	0.100	0.064	0.040	0.026	0.016	0.010	20%
25%	4.8%	1.50	1.25	1.13	1.00	0.88	0.63	0.50	0.31	0.200	0.125	0.080	0.050	0.033	0.020	0.013	25%
30%	5.9%	1.80	1.50	1.35	1.20	1.05	0.75	0.60	0.38	0.240	0.150	0.096	0.060	0.039	0.024	0.015	30%
40%	8.8%	2.40	2.00	1.80	1.60	1.40	1.00	0.80	0.50	0.320	0.200	0.128	0.080	0.052	0.032	0.020	40%
50%	13.2%	3.00	2.50	2.25	2.00	1.75	1.25	1.00	0.63	0.400	0.250	0.160	0.100	0.065	0.040	0.025	50%
60%	19.8%	3.60	3.00	2.70	2.40	2.10	1.50	1.20	0.75	0.480	0.300	0.192	0.120	0.078	0.048	0.030	60%
70%	29.6%	4.20	3.50	3.15	2.80	2.45	1.75	1.40	0.88	0.560	0.350	0.224	0.140	0.091	0.056	0.035	70%
75%	36.3%	4.50	3.75	3.38	3.00	2.63	1.88	1.50	0.94	0.600	0.375	0.240	0.150	0.098	0.060	0.038	75%
80%	44.4%	4.80	4.00	3.60	3.20	2.80	2.00	1.60	1.00	0.640	0.400	0.256	0.160	0.104	0.064	0.040	80%
90%	66.7%	5.40	4.50	4.05	3.60	3.15	2.25	1.80	1.13	0.720	0.450	0.288	0.180	0.117	0.072	0.045	90%
100%	100%	6.00	5.00	4.50	4.00	3.50	2.50	2.00	1.25	0.800	0.500	0.320	0.200	0.130	0.080	0.050	100%
Valve Sizes		1"	1"	1"	1", 3/4"	1", 3/4"	1-1/2"	1-1/2"	1-1/2"	1-1/2"	1-1/2"	1-1/4"	1-1/4"	1-1/4"	1-1/4"	1-1/4"	

Numbers are for reference or comparison only.

Research Control Valves

CV vs Lift Curve

% Lift	% Maximum Cv	
	Linear	Equal %
0%	0%	0%
5%	5%	1%
10%	10%	2%
20%	20%	4%
25%	25%	5%
30%	30%	6%
40%	40%	9%
50%	50%	13%
60%	60%	20%
70%	70%	30%
75%	75%	36%
80%	80%	44%
90%	90%	67%
100%	100%	100%

