

Cryogenic and High Temperature Valve

U.S. Type 973 (Includes Sub-CFL)

DESCRIPTION

The U.S. Type 973 globe control valve is designed for modulating flow control in industrial or research applications at 1000° F (537° C) or less and at pressures less than 5000 psi (344 bar). The added bonnet length and fins serve to reduce the heat at the packing area. The reduction in heat allows the standard CV ring packing to be used at higher process temperatures than could normally be tolerated with the standard valve.

APPLICATIONS

Type 973 valves are widely used in high temperature applications where steam, hot water, hot hydraulic oil or other fluids and gases must be controlled precisely at temperatures exceeding the limits of the standard finned bonnet valve.

Follow the appropriate pressure and temperature rating of the body material and the packing and trim material. See "Pressure vs Temperature Ratings for Valve Superstructure" on page 2.

MATERIALS

| Body – Bonnet | |
|---------------|--|
| Standard | 316 stainless steel, carbon steel (WCB) |
| Optional | Monel®, Alloy 20, Hastelloy® C and B or ASTM equivalent |
| Innervalue | |
| Standard | 316 stainless steel |
| Optional | Stellite®, Monel, Alloy 20, Hastelloy C and B or ASTM equivalent |
| Packing | |
| Standard | TFE chevron rings |
| Optional | Graphite |
| Actuator | |
| | Die cast aluminum |
| | 316L stainless steel on standard 1/2 in. (12.7 mm) models |

ACTUATOR CHOICES

| | |
|-------------------------|---|
| Standard | Air-to-open, fail close Air-to-close, fail open |
| Optional | With integral top mounted positioner |
| Standard Signals | 3-15#, 3-27#, 6-30# |
| Optional Signals | 3-9#, 9-15#, with positioner |
| Accessories | Filter regulator, gauges, I/P converter, limit switches, handwheel, solenoids |



Shown with Type 754 Actuator

STANDARD FEATURES

- 1/4 in. (6 mm), 1/2 in. (12 mm), 3/4 in. (19 mm) and 1 in. (25 mm) models
- Interchangeable trim sets
- Extended cooling fin bonnet
- Trim characteristics: Linear, equal percent, quick open or double taper
- TFE chevron packing
- ANSI Class IV shutoff (size O and larger)
- High temperature rating

OPTIONAL FEATURES

- Butt and socket weld ends, BSPP, tube connection and others
- Bellows packing solutions
- Angle pattern body
- Reduced Emissions Kalrez® (REK), graphite, spring-loaded chevron and others
- Exotic alloys for complete valves or trims
- Stellite trims & soft seats (PTFE & Kel-F)
- TiN coating of innervalue stem and seat

PRESSURE VS TEMPERATURE RATINGS FOR VALVE SUPERSTRUCTURE

The pressure/temperature ratings are based on material cross sections at the joint between the body and bonnet where a gasketed screwed type bonnet is used. When the proper torque levels are used, the valve should not experience rupture of the joint or the material. The torque levels were used in hydrostatic tests at the factory at 70° F (21.1° C) at maximum body rating and were found to provide acceptable seating. Other factors, such as high or cyclic temperatures, light process gases, or poor gasket surfaces can dictate the ability of a seal to be made. Under such conditions, the only way to be sure of tight sealing is to perform a test under the actual process conditions.

The following tables exclude packing or end fittings:

| 1/4 in. (6.4 mm) Research Control Valve | | | | | | |
|---|--|---------------------------|-------------------------------|-------------------------------|--------------------|-----------------------|
| Temp | 316 S/S psi (bar) | Carbon Steel psi (bar) | Hastelloy B or = psi (bar) | Hastelloy C or = psi (bar) | Monel psi (bar) | Alloy 20 psi (bar) |
| 100° F (37.8° C) | 5000 (345) | 4000 (276) | 5000 (345) | 5000 (345) | 4000 (276) | 5000 (345) |
| 200° F (93.3° C) | 5000 (345) | 3700 (255) | 5000 (345) | 5000 (345) | 4000 (276) | 5000 (345) |
| 300° F (148.9° C) | 4750 (328) | 3500 (241) | 5000 (345) | 5000 (345) | 3880 (268) | 4850 (334) |
| 400° F (204.4° C) | 4190 (289) | 3200 (221) | 5000 (345) | 5000 (345) | 3770 (260) | 4700 (324) |
| 500° F (260° C) | 4000 (276) | 2900 (200) | 4900 (338) | 4900 (338) | 3740 (258) | 4500 (310) |
| 600° F (315.6° C) | 3820 (263) | 2600 (179) | 4850 (334) | 4850 (334) | 3740 (258) | 4200 (290) |
| 700° F (371.1° C) | 3640 (251) | 2300 (159) | 4800 (331) | 4800 (331) | 3640 (251) | 3900 (269) |
| 800° F (426.7° C) | 3580 (267) | — | 4750 (328) | 4750 (328) | 3580 (267) | 3700 (255) |
| 900° F (482.2° C) | 2840 (196) | — | — | 4500 (310) | 2280 (157) | 3000 (207) |
| 1000° F (537.8° C) | 1160 (80) | — | — | 4000 (276) | 940 (65) | 1500 (103) |
| 1100° F (593.3° C) | Consult factory for higher temperatures. | | | 3500 (241) | — | — |
| 1200° F (648.9° C) | | | | 3000 (207) | — | — |
| Recommended torque in ft-lb (Nm), +/- 2 ft-lb (2.71 Nm) | | | | | | |
| | 37 (50) | 37 (50) | 39 (53) | 37 (50) | 31 (42) | 35 (47) |

| 1/2 in. (12.7 mm) Research Control Valve | | | | | | |
|---|--|---------------------------|-------------------------------|-------------------------------|--------------------|-----------------------|
| Temp | 316 S/S psi (bar) | Carbon Steel psi (bar) | Hastelloy B or = psi (bar) | Hastelloy C or = psi (bar) | Monel psi (bar) | Alloy 20 psi (bar) |
| 100° F (37.8° C) | 5000 (345) | 4000 (276) | 5000 (345) | 5000 (345) | 4000 (276) | 5000 (345) |
| 200° F (93.3° C) | 4750 (328) | 3800 (262) | 5000 (345) | 5000 (345) | 3780 (261) | 5000 (345) |
| 300° F (148.9° C) | 4310 (297) | 3600 (248) | 5000 (345) | 5000 (345) | 3520 (243) | 4950 (341) |
| 400° F (204.4° C) | 3860 (266) | 3300 (228) | 5000 (345) | 5000 (345) | 3420 (236) | 4850 (334) |
| 500° F (260° C) | 3640 (251) | 3100 (2140) | 4900 (338) | 4900 (338) | 3390 (234) | 4600 (317) |
| 600° F (315.6° C) | 3470 (239) | 2900 (200) | 4870 (336) | 4870 (336) | 3390 (234) | 4300 (296) |
| 700° F (371.1° C) | 3310 (228) | 2700 (186) | 4810 (332) | 4610 (318) | 3310 (228) | 4200 (290) |
| 800° F (426.7° C) | 3255 (224) | — | 4430 (305) | 4430 (305) | 2090 (144) | 4000 (276) |
| 900° F (482.2° C) | 3190 (220) | — | — | 4200 (290) | 2070 (143) | 3000 (207) |
| 1000° F (537.8° C) | 1860 (128) | — | — | 4000 (276) | 850 (59) | 1500 (103) |
| 1100° F (593.3° C) | Consult factory for higher temperatures. | | | 3400 (234) | — | — |
| 1200° F (648.9° C) | | | | 3000 (207) | — | — |
| Recommended torque in ft-lb (Nm), +/- 2 ft-lb (2.71 Nm) | | | | | | |
| | 122 (165) | 122 (165) | 131 (178) | 124 (168) | 102 (138) | 117 (159) |

| 3/4 in. (19.1 mm) and 1 in. (25.4 mm) Research Control Valve | | | | |
|---|-------------------|-----------------|-------------------|-----------------|
| Temp | 316 S/S | | Carbon Steel | |
| | 3/4 in. (19.1 mm) | 1 in. (25.4 mm) | 3/4 in. (19.1 mm) | 1 in. (25.4 mm) |
| 100° F (37.8° C) | 1500 (103) | 1500 (103) | 1500 (103) | 1500 (103) |
| 200° F (93.3° C) | 1450 (100) | 1450 (100) | 1350 (93) | 1350 (93) |
| 300° F (148.9° C) | 1325 (91) | 1325 (91) | 1325 (91) | 1325 (91) |
| 400° F (204.4° C) | 1175 (81) | 1175 (81) | 1275 (88) | 1275 (88) |
| 500° F (260° C) | 1100 (76) | 1100 (76) | 1200 (83) | 1200 (83) |
| 600° F (315.6° C) | 1070 (74) | 675 (47) | 1100 (76) | 1100 (76) |
| 700° F (371.1° C) | 840 (58) | 250 (17) | 1075 (74) | 1075 (74) |
| 800° F (426.7° C) | 575 (40) | — | — | — |
| 3/4 in. (19.1 mm) and 1 in. (25.4 mm) Torque = 290 ft-lb (393 Nm) | | | | |

DIMENSIONS

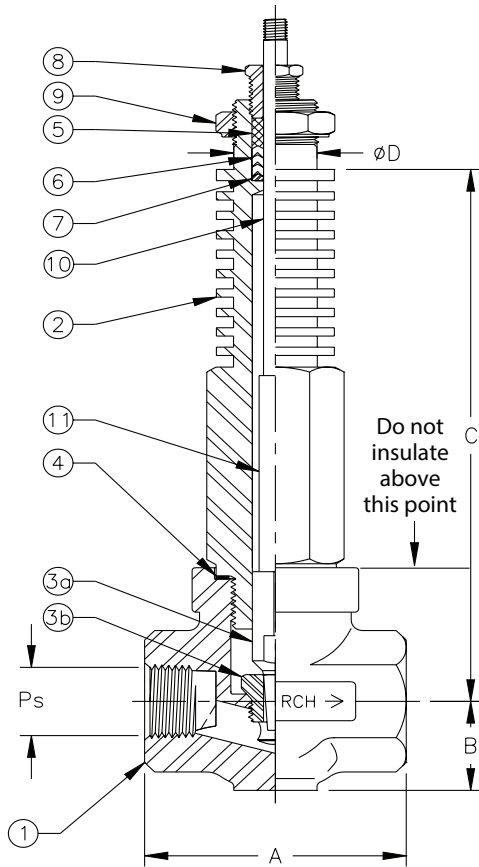

1. Valve Body (Investment cast, NPT ends)
2. Valve Bonnet: 1/4 in. (6.4 mm) = 7/8 in. (22.2 mm) hex;
1/2 in. (12.7 mm) = 1-1/4 in. (31.8 mm) hex;
3/4 in. (19.1 mm) = 1-1/2 in. (38.1 mm) hex;
1 in. (25.4 mm) = 1-3/4 in. (44.5 mm) hex.
(Some exotic materials may use round material.)
3. Innavelve (trim set)
 - a. Plug
 - b. Seat: 1/4 in. (6.4 mm) = 3/8 in. (9.5 mm) hex;
1/2 in. (12.7 mm) = 5/8 in. (15.9 mm) hex;
3/4 in. (19.1 mm) = 3/4 in. (19.1 mm) hex ;
1 in. (25.4 mm) = 15/16 in. (23.8 mm) hex
4. Body Bonnet Gasket (may not be supplied in exotic material)
5. Packing Adaptor (CV ring packing only)
6. Packing (CV ring)
7. Packing Follower (CV ring packing only)
8. Packing Gland: 1/4 in. (6.4 mm) = 7/16 in. (11.1 mm) hex;
1/2 in. (12.7 mm) = 1/2 in. (12.7 mm) hex;
3/4 in. (19.1 mm) = 1/2 in. (12.7 mm) hex;
1 in. (25.4 mm) = 1/2 in. (12.7 mm) hex
9. Yoke Lock Nut: 1/4 in. (6.4 mm) = 7/8 in. (22.2 mm) hex;
1/2 in. (12.7 mm) = 1-1/8 in. (28.8 mm) hex;
3/4 in. (19.1 mm) = 1-1/8 in. (28.8 mm) hex;
1 in. (25.4 mm) = 1-1/8 in. (28.8 mm) hex
10. Stem connector: 1/4 in. (6.4 mm) = 1/4 in. (6.4 mm) hex;
1/2 in. (12.7 mm) = 3/8 in. (9.5 mm) hex;
3/4 in. (19.1 mm) = 3/8 in. (9.5 mm) hex;
1 in. (25.4 mm) = 3/8 in. (9.5 mm) hex
11. Upper Stem

| PS | A | B | C | D | Stroke |
|--------------------|---------------------|--------------------|---------------------|---------------------|---------------------|
| 0.25 in. (6.4 mm) | 2.12 in. (53.8 mm) | 0.68 in. (17.3 mm) | 4.00 in. (101.6 mm) | 0.625 in. (15.9 mm) | 0.437 in. (11.1 mm) |
| 0.50 in. (12.7 mm) | 2.75 in. (69.8 mm) | 1.00 in. (25.4 mm) | 6.00 in. (152.4 mm) | 0.875 in. (22.2 mm) | 0.562 in. (14.3 mm) |
| 0.75 in. (19.1 mm) | 3.37 in. (85.6 mm) | 1.18 in. (30.0 mm) | | | |
| 1 in. (25.4 mm) | 4.00 in. (101.6 mm) | 1.50 in. (38.1 mm) | | | |

INNERVALVE CHART

| Valve Size | Trim Designation | Nominal Cv | Theoretical Turbulent Cv | Orifice Dia. | Orifice Area | Nominal Rangeability | |
|--|--|------------|--------------------------|----------------------|--|--|---------|
| | | | | | | Linear | Equal % |
| 1 in. (25.4 mm) | 6.0 | 6.0 | 6.0 | 0.6250 in. (15.9 mm) | 0.3068 in. ² (197.9 mm ²) | 50:1 | 60:1 |
| | 5.0 | 5.0 | 5.0 | 0.6250 in. (15.9 mm) | 0.3068 in. ² (197.9 mm ²) | 50:1 | 60:1 |
| | 4.5 | 4.5 | 4.5 | 0.5000 in. (12.7 mm) | 0.1963 in. ² (126.6 mm ²) | 50:1 | 60:1 |
| 3/4 in. (19.1 mm) and 1 in. (25.4 mm) | 4.0 | 4.0 | 4.0 | 0.5000 in. (12.7 mm) | 0.1963 in. ² (126.6 mm ²) | 50:1 | 60:1 |
| | 3.5 | 3.5 | 3.5 | 0.5000 in. (12.7 mm) | 0.1963 in. ² (126.6 mm ²) | 50:1 | 60:1 |
| 1/2 in. (12.7 mm), 3/4 in. (19.1 mm) and 1 in. (25.4 mm) | A | 2.5 | 2.5/2.2 | 0.3750 in. (9.5 mm) | 0.1104 in. ² (71.2 mm ²) | 40:1 | 50:1 |
| | B | 2.0 | 2.0 | 0.3750 in. (9.5 mm) | 0.1104 in. ² (71.2 mm ²) | 40:1 | 50:1 |
| | C | 1.25 | 1.25 | 0.2810 in. (7.1 mm) | 0.0620 in. ² (40.0 mm ²) | 40:1 | 50:1 |
| | D | 0.8 | 0.80 | 0.2500 in. (6.4 mm) | 0.0491 in. ² (31.7 mm ²) | 40:1 | 50:1 |
| | E | 0.5 | 0.50 | 0.2500 in. (6.4 mm) | 0.0491 in. ² (31.7 mm ²) | 40:1 | 50:1 |
| 1/4 in. (6.4 mm), 1/2 in. (12.7 mm), 3/4 in. (19.1 mm) and 1 in. (25.4 mm) | F | 0.32 | 0.32 | 0.1560 in. (3.9 mm) | 0.0191 in. ² (12.3 mm ²) | 30:1 | 40:1 |
| | G | 0.2 | 0.20 | 0.1560 in. (3.9 mm) | 0.0191 in. ² (12.3 mm ²) | 30:1 | 40:1 |
| | H | 0.13 | 0.13 | 0.1560 in. (3.9 mm) | 0.0191 in. ² (12.3 mm ²) | 30:1 | 40:1 |
| | I | 0.08 | 0.08 | 0.1560 in. (3.9 mm) | 0.0191 in. ² (12.3 mm ²) | 30:1 | 40:1 |
| | J | 0.05 | 0.05 | 0.1560 in. (3.9 mm) | 0.0191 in. ² (12.3 mm ²) | 30:1 | 40:1 |
| | K | 0.03 | 4.8E-02 | 0.0860 in. (2.2 mm) | 0.0058 in. ² (3.7 mm ²) | 25:1 | — |
| | L | 0.02 | 3.4E-02 | 0.0860 in. (2.2 mm) | 0.0058 in. ² (3.7 mm ²) | 25:1 | — |
| | M | 0.01 | 1.6E-02 | 0.0860 in. (2.2 mm) | 0.0058 in. ² (3.7 mm ²) | 25:1 | — |
| | N | 0.006 | 1.0E-02 | 0.0860 in. (2.2 mm) | 0.0058 in. ² (3.7 mm ²) | 25:1 | — |
| | O | 0.003 | 5.3E-03 | 0.0860 in. (2.2 mm) | 0.0058 in. ² (3.7 mm ²) | 25:1 | — |
| | 1/4 in. (6.4 mm) and 1/2 in. (12.7 mm) | P1 | 0.002 | 3.6E-03 | 0.0625 in. (1.6 mm) | 0.0031 in. ² (2.0 mm ²) | 15:1 |
| P2 | | 0.0013 | 2.5E-03 | 0.0625 in. (1.6 mm) | 0.0031 in. ² (2.0 mm ²) | 15:1 | — |
| P3 | | 0.001 | 2.0E-03 | 0.0625 in. (1.6 mm) | 0.0031 in. ² (2.0 mm ²) | 15:1 | — |
| P4 | | 0.0006 | 1.4E-03 | 0.0625 in. (1.6 mm) | 0.0031 in. ² (2.0 mm ²) | 15:1 | — |
| P5 | | 0.0004 | 1.0E-03 | 0.0625 in. (1.6 mm) | 0.0031 in. ² (2.0 mm ²) | 15:1 | — |
| P6 | | 0.00027 | 8.3E-04 | 0.0625 in. (1.6 mm) | 0.0031 in. ² (2.0 mm ²) | 15:1 | — |
| P7 | | 0.00018 | 6.8E-04 | 0.0625 in. (1.6 mm) | 0.0031 in. ² (2.0 mm ²) | 15:1 | — |
| P8 | | 0.00012 | 5.6E-04 | 0.0625 in. (1.6 mm) | 0.0031 in. ² (2.0 mm ²) | 15:1 | — |
| P9 | | 0.00008 | 4.6E-04 | 0.0625 in. (1.6 mm) | 0.0031 in. ² (2.0 mm ²) | 15:1 | — |
| 1/4 in. (6.4 mm) | P10 | 0.00005 | 1.9E-04 | 0.0420 in. (1.1 mm) | 0.0014 in. ² (0.9 mm ²) | 15:1 | — |
| | P11 | 0.000036 | 1.6E-04 | 0.0420 in. (1.1 mm) | 0.0014 in. ² (0.9 mm ²) | 15:1 | — |
| | P12 | 0.000024 | 1.3E-04 | 0.0420 in. (1.1 mm) | 0.0014 in. ² (0.9 mm ²) | 15:1 | — |
| | P13 | 0.000016 | 1.1E-04 | 0.0420 in. (1.1 mm) | 0.0014 in. ² (0.9 mm ²) | 15:1 | — |
| | P14 | 0.00001 | 8.4E-05 | 0.0420 in. (1.1 mm) | 0.0014 in. ² (0.9 mm ²) | 15:1 | — |
| | P15 | 0.000006 | 6.6E-05 | 0.0420 in. (1.1 mm) | 0.0014 in. ² (0.9 mm ²) | 15:1 | — |
| | P16 | 0.000004 | 5.3E-05 | 0.0420 in. (1.1 mm) | 0.0014 in. ² (0.9 mm ²) | 15:1 | — |
| | P17 | 0.0000027 | 4.4E-05 | 0.0420 in. (1.1 mm) | 0.0014 in. ² (0.9 mm ²) | 15:1 | — |
| | P18 | 0.0000018 | 3.6E-05 | 0.0420 in. (1.1 mm) | 0.0014 in. ² (0.9 mm ²) | 15:1 | — |

K...O and the P-series trims are considered reduced trims when installed in a 1/2 in. (12.7 mm) valve. Occasionally, P1...P9 trims are made on a 0.042 in. (1.1 mm) orifice.

PACKING/MEDIA TEMPERATURE

IMPORTANT

To prevent the stem from freezing, avoid packing temperatures below 0° C (32° F).

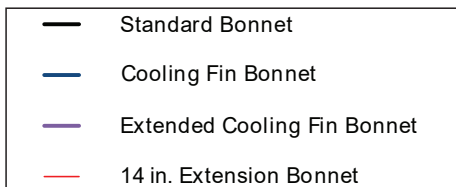
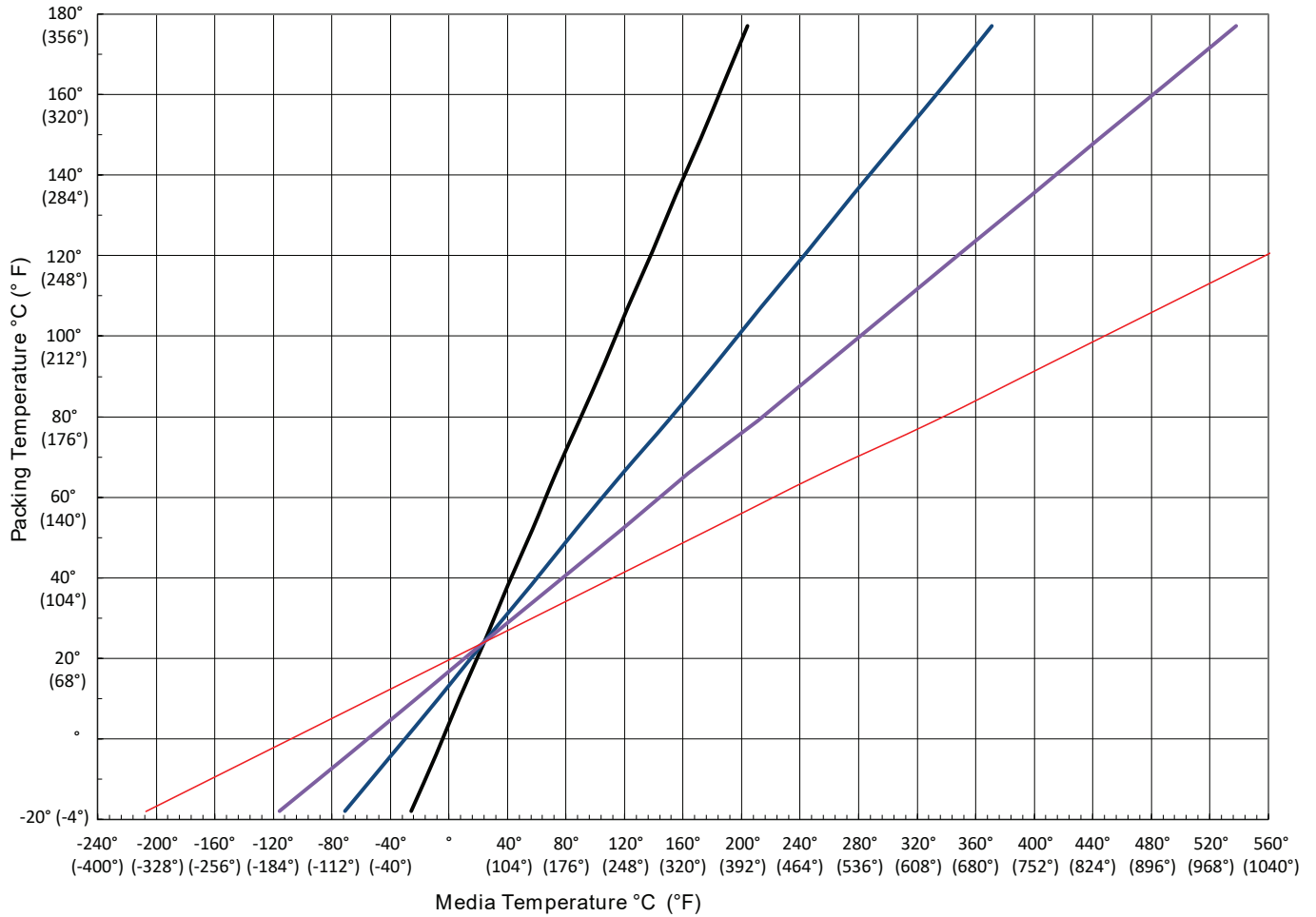

DESCRIPTION

The Type NRMA Non-Rotating Manual Actuation design is used in applications where either our low-flow trims, cooling fins or bellows are needed and when applications demand human interaction. The manual actuator can be mounted on all RC series valves, including all "P" Trims and all Bonnets. Exchanging between electrical, pneumatic and manual actuators is therefore possible at any time with simple additions. The actuator is encapsulated and completely maintenance-free—designed for fine control.

APPLICATIONS

When you turn the hand wheel, the valve interior moves in a linear motion. This linear movement, from the hand wheel to the internal coupling, prevents damage to the trim and seat, distinguishing this design from conventional manual control valves.

FEATURES

- Hand drive, linear
- Suitable for Badger Meter® modular construction

MATERIALS

| | |
|-------------------|---------------|
| Case | 1.4404 (316L) |
| Yoke | 1.4404 (316L) |
| Hand Wheel | Duroplast |

SPECIFICATIONS

| | |
|--------------------|-------------------------------|
| Weight | Approximately 3.3 lb (1.5 kg) |
| Temperature | -40...176° F (-40...80° C) |
| Valve Lift | 0.04 in. (1 mm) / 360° turn |

SIZES FOR RESEARCH CONTROL VALVES

| Sizes | Ø Average | Stroke |
|--|-----------|---------|
| 1/4 in. standard | 0.625 in. | 11.1 mm |
| 1/2 in., 3/4 in., 1 in. standard | 0.875 in. | 14.3 mm |
| 1/2 in., 3/4 in., 1 in. heavy duty guiding | 0.875 in. | 14.3 mm |



DIMENSIONS

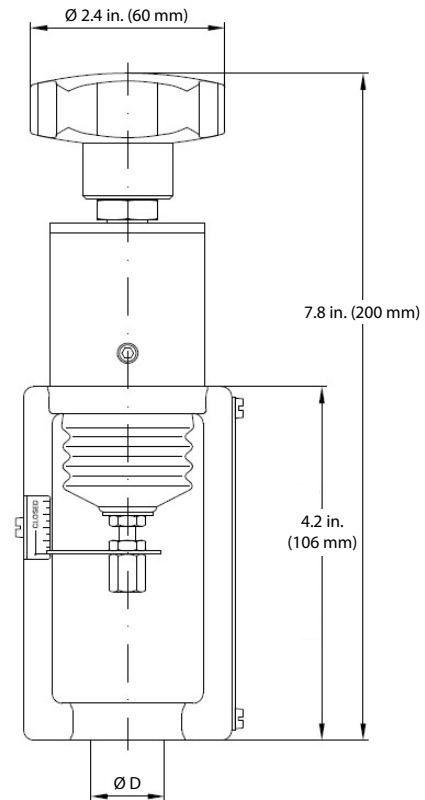

| RCV Valves | | Trim Sizes Equal % | | | | | | | | | | | | | | | |
|-------------|-------|--------------------|------|------|----------|----------|--------|--------|--------|--------|--------|--------|--------|--------|--------|--------|--------|
| % Lift | % Cv | 6.0 | 5 | 4.5 | 4 | 3.5 | A | B | C | D | E | F | G | H | I | J | % Lift |
| 0% | 0% | 0 | 0 | 0 | 0 | 0 | 0 | 0 | 0 | 0 | 0 | 0 | 0 | 0 | 0 | 0 | 0% |
| 5% | 1.0% | 0.06 | 0.05 | 0.04 | 0.04 | 0.03 | 0.02 | 0.02 | 0.01 | 0.008 | 0.005 | 0.003 | 0.002 | 0.001 | 0.001 | 0.000 | 5% |
| 10% | 1.9% | 0.11 | 0.10 | 0.09 | 0.08 | 0.07 | 0.05 | 0.04 | 0.02 | 0.015 | 0.010 | 0.006 | 0.004 | 0.002 | 0.002 | 0.001 | 10% |
| 20% | 3.8% | 0.23 | 0.19 | 0.17 | 0.15 | 0.13 | 0.10 | 0.08 | 0.05 | 0.031 | 0.019 | 0.012 | 0.008 | 0.005 | 0.003 | 0.002 | 20% |
| 25% | 4.8% | 0.29 | 0.24 | 0.22 | 0.19 | 0.17 | 0.12 | 0.10 | 0.06 | 0.038 | 0.024 | 0.015 | 0.010 | 0.006 | 0.004 | 0.002 | 25% |
| 30% | 5.9% | 0.35 | 0.29 | 0.26 | 0.23 | 0.20 | 0.15 | 0.12 | 0.07 | 0.047 | 0.029 | 0.019 | 0.012 | 0.008 | 0.005 | 0.003 | 30% |
| 40% | 8.8% | 0.53 | 0.44 | 0.40 | 0.35 | 0.31 | 0.22 | 0.18 | 0.11 | 0.070 | 0.044 | 0.028 | 0.018 | 0.011 | 0.007 | 0.004 | 40% |
| 50% | 13.2% | 0.79 | 0.66 | 0.59 | 0.53 | 0.46 | 0.33 | 0.26 | 0.16 | 0.105 | 0.066 | 0.042 | 0.026 | 0.017 | 0.011 | 0.007 | 50% |
| 60% | 19.8% | 1.19 | 0.99 | 0.89 | 0.79 | 0.69 | 0.49 | 0.40 | 0.25 | 0.158 | 0.099 | 0.063 | 0.040 | 0.026 | 0.016 | 0.010 | 60% |
| 70% | 29.6% | 1.78 | 1.48 | 1.33 | 1.19 | 1.04 | 0.74 | 0.59 | 0.37 | 0.237 | 0.148 | 0.095 | 0.059 | 0.039 | 0.024 | 0.015 | 70% |
| 75% | 36.3% | 2.18 | 1.81 | 1.63 | 1.45 | 1.27 | 0.91 | 0.73 | 0.45 | 0.290 | 0.181 | 0.116 | 0.073 | 0.047 | 0.029 | 0.018 | 75% |
| 80% | 44.4% | 2.67 | 2.22 | 2.00 | 1.78 | 1.56 | 1.11 | 0.89 | 0.56 | 0.356 | 0.222 | 0.142 | 0.089 | 0.058 | 0.036 | 0.022 | 80% |
| 90% | 66.7% | 4.00 | 3.33 | 3.00 | 2.67 | 2.33 | 1.67 | 1.33 | 0.83 | 0.533 | 0.333 | 0.213 | 0.133 | 0.087 | 0.053 | 0.033 | 90% |
| 100% | 100% | 6.00 | 5.00 | 4.50 | 4.00 | 3.50 | 2.50 | 2.00 | 1.25 | 0.800 | 0.500 | 0.320 | 0.200 | 0.130 | 0.080 | 0.050 | 100% |
| Valve Sizes | | 1" | 1" | 1" | 1", 3/4" | 1", 3/4" | 1-1/2" | 1-1/2" | 1-1/2" | 1-1/2" | 1-1/2" | 1-1/4" | 1-1/4" | 1-1/4" | 1-1/4" | 1-1/4" | |

Trim Sizes O through P-18 are available only in linear characteristic. See Product Data Sheets for maximum Cvs.

| RCV Valves | | Trim Sizes Equal % | | | | | | | | | | | | | | | |
|-------------|-------|--------------------|------|------|----------|----------|--------|--------|--------|--------|--------|--------|--------|--------|--------|--------|--------|
| % Lift | % Cv | 6.0 | 5 | 4.5 | 4 | 3.5 | A | B | C | D | E | F | G | H | I | J | % Lift |
| 0% | 0% | 0 | 0 | 0 | 0 | 0 | 0 | 0 | 0 | 0 | 0 | 0 | 0 | 0 | 0 | 0 | 0% |
| 5% | 1.0% | 0.30 | 0.25 | 0.23 | 0.20 | 0.18 | 0.13 | 0.10 | 0.06 | 0.040 | 0.025 | 0.016 | 0.010 | 0.007 | 0.004 | 0.003 | 5% |
| 10% | 1.9% | 0.60 | 0.50 | 0.45 | 0.40 | 0.35 | 0.25 | 0.20 | 0.13 | 0.080 | 0.050 | 0.032 | 0.020 | 0.013 | 0.008 | 0.005 | 10% |
| 20% | 3.8% | 1.20 | 1.00 | 0.90 | 0.80 | 0.70 | 0.50 | 0.40 | 0.25 | 0.160 | 0.100 | 0.064 | 0.040 | 0.026 | 0.016 | 0.010 | 20% |
| 25% | 4.8% | 1.50 | 1.25 | 1.13 | 1.00 | 0.88 | 0.63 | 0.50 | 0.31 | 0.200 | 0.125 | 0.080 | 0.050 | 0.033 | 0.020 | 0.013 | 25% |
| 30% | 5.9% | 1.80 | 1.50 | 1.35 | 1.20 | 1.05 | 0.75 | 0.60 | 0.38 | 0.240 | 0.150 | 0.096 | 0.060 | 0.039 | 0.024 | 0.015 | 30% |
| 40% | 8.8% | 2.40 | 2.00 | 1.80 | 1.60 | 1.40 | 1.00 | 0.80 | 0.50 | 0.320 | 0.200 | 0.128 | 0.080 | 0.052 | 0.032 | 0.020 | 40% |
| 50% | 13.2% | 3.00 | 2.50 | 2.25 | 2.00 | 1.75 | 1.25 | 1.00 | 0.63 | 0.400 | 0.250 | 0.160 | 0.100 | 0.065 | 0.040 | 0.025 | 50% |
| 60% | 19.8% | 3.60 | 3.00 | 2.70 | 2.40 | 2.10 | 1.50 | 1.20 | 0.75 | 0.480 | 0.300 | 0.192 | 0.120 | 0.078 | 0.048 | 0.030 | 60% |
| 70% | 29.6% | 4.20 | 3.50 | 3.15 | 2.80 | 2.45 | 1.75 | 1.40 | 0.88 | 0.560 | 0.350 | 0.224 | 0.140 | 0.091 | 0.056 | 0.035 | 70% |
| 75% | 36.3% | 4.50 | 3.75 | 3.38 | 3.00 | 2.63 | 1.88 | 1.50 | 0.94 | 0.600 | 0.375 | 0.240 | 0.150 | 0.098 | 0.060 | 0.038 | 75% |
| 80% | 44.4% | 4.80 | 4.00 | 3.60 | 3.20 | 2.80 | 2.00 | 1.60 | 1.00 | 0.640 | 0.400 | 0.256 | 0.160 | 0.104 | 0.064 | 0.040 | 80% |
| 90% | 66.7% | 5.40 | 4.50 | 4.05 | 3.60 | 3.15 | 2.25 | 1.80 | 1.13 | 0.720 | 0.450 | 0.288 | 0.180 | 0.117 | 0.072 | 0.045 | 90% |
| 100% | 100% | 6.00 | 5.00 | 4.50 | 4.00 | 3.50 | 2.50 | 2.00 | 1.25 | 0.800 | 0.500 | 0.320 | 0.200 | 0.130 | 0.080 | 0.050 | 100% |
| Valve Sizes | | 1" | 1" | 1" | 1", 3/4" | 1", 3/4" | 1-1/2" | 1-1/2" | 1-1/2" | 1-1/2" | 1-1/2" | 1-1/4" | 1-1/4" | 1-1/4" | 1-1/4" | 1-1/4" | |

Numbers are for reference or comparison only.

| % Lift | % Maximum Cv | |
|--------|--------------|---------|
| | Linear | Equal % |
| 0% | 0% | 0% |
| 5% | 5% | 1% |
| 10% | 10% | 2% |
| 20% | 20% | 4% |
| 25% | 25% | 5% |
| 30% | 30% | 6% |
| 40% | 40% | 9% |
| 50% | 50% | 13% |
| 60% | 60% | 20% |
| 70% | 70% | 30% |
| 75% | 75% | 36% |
| 80% | 80% | 44% |
| 90% | 90% | 67% |
| 100% | 100% | 100% |

% Cv vs. % Lift

