

DESCRIPTION

The U.S. Type SCV-89 Research Control® Valves are compact control valves designed to meet the manufacturing standards established by the 3A Symbol Council. The standard investment cast body provides a unit that is lightweight and economical.

APPLICATIONS

Valves of the SCV-89 type are well suited to automated control systems found in biotechnology, pharmaceutical and food processes.

- Pressure
- Temperature
- Product injection
- Flow control in fermentation reactors
- Control of gas blankets in closed vessels
- Catalyst, defoamer and additive initiation

MATERIALS OF CONSTRUCTION

Size	1 in. (25.4 mm) and 1-1/2 in. (38.1 mm)	
Body - Bonnet	Body	316/316L Stainless Steel Cast
	Bonnet	316 Stainless Steel Barstock
Innervalve	316 Stainless Steel Barstock Trims	
Clamps	304 or 316 Stainless Steel	
Gaskets	Standard	Viton (FKM)
	Optional	Silicone, EPDM or Kalrez
O-Rings	Standard	Viton (FKM)
	Optional	Silicone, EPDM or Kalrez
Actuator Housing	Standard	Epoxy Coated Aluminum
	Optional	316/316L Stainless Steel

STANDARD FEATURES

- Manufactured to 3A Symbol standards
- Self-draining design
- Quick disassembly with clamps
- Tri-Clamp® connection®
- Designed for steam-in-place and clean-in-place
- Internal Finish: 16 Ra

OTHER AVAILABLE VALVES

Research Control Valves manufactures many different models of both standard and specialty control valves, conventional as well as sanitary designs. If your needs for small control valves can be served with a custom designed valve, please contact your area representative for assistance.



Badger Meter

RCV-DS-03803-EN-02 (August 2022)



ACTUATOR CHOICES

Standard	Air-to-open, fail close Air-to-close, fail open
Optional	Stainless Steel Actuator
	ATO or ATC with integral top mounted positioner
	ATO or ATC with side mounted positioner
Signal Ranges	3-15#, 3-27#, 6-30# (3-9#, 9-15# with positioner)
Electronic Actuator	We offer a wide choice of electric actuators up to 200 pounds of thrust.

SPECIFICATIONS

Pressure/Temperature Rating	300 psi at 75° F	
	150 psi at 300° F	
Finishes	Internal	16 Ra
	External	As cast (electropolished)
Consult the factory for maximum allowable flowing and shutoff pressures		

PARTS AND DIMENSIONS

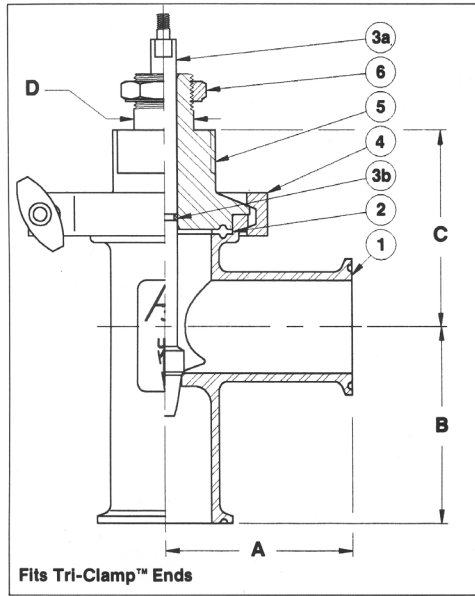

Item Description

1	Body
2	Body-Bonnet gasket
3a	Innervalve/stem (1 piece)
3b	O-ring
4	Body-Bonnet clamp
5	Bonnet
6	Yoke locknut

Dimensions

PS	1 in. (25.4 mm)	1-1/2 in. (38.1 mm)
A	2.75 in. (69.9 mm)	2.75 in. (69.9 mm)
B	2.63 in. (66.8 mm)	2.87 in. (72.9 mm)
C	3.10 in. (78.7 mm)	2.86 in. (72.6 mm)
D	0.875 in. (22.2 mm)	0.875 in. (22.2 mm)
Stroke Length	0.562 in. (14.3 mm)	

Valve Numbers

Size	Valve No.	Dwg. No.
1 in. (25.4 mm)	940	CD-950940
1-1/2 in. (38.1 mm)	935	CD-950935

INNERVALVE CHART

Valve Size	Trim Designation	CV	KV	Nom. Rangeability		Orifice Port Diameter	Port Area (in. ²)
		Coefficient		Linear	(=%)		
1-1/2 in. (38.1 mm)	20	20.00	17.24	40:1	60:1	1.00 in. (25.4 mm)	0.7854
	15	15.00	12.93	40:1	60:1	1.00 in. (25.4 mm)	0.7854
1 in. (25.4 mm), 1-1/2 in. (38.1 mm)	10	10.00	8.62	40:1	60:1	0.75 in. (19.1 mm)	0.4420
	8	8.00	6.90	40:1	60:1	0.75 in. (19.1 mm)	0.4420
	6	6.00	5.17	40:1	60:1	0.75 in. (19.1 mm)	0.4420
	5	5.00	4.31	40:1	60:1	0.50 in. (12.7 mm)	0.1964
	4	4.00	3.45	40:1	60:1	0.50 in. (12.7 mm)	0.1964
	A	3.00	2.59	40:1	60:1	0.50 in. (12.7 mm)	0.1964
	B	2.00	1.72	40:1	60:1	0.375 in. (9.5 mm)	0.1105
	C	1.25	1.08	40:1	60:1	0.375 in. (9.5 mm)	0.1105
	D	0.80	0.69	40:1	60:1	0.375 in. (9.5 mm)	0.1105
	E	0.50	0.43	40:1	60:1	0.375 in. (9.5 mm)	0.1105
	F	0.32	0.28	30:1	40:1	0.156 in. (4.0 mm)	0.0192
	G	0.20	0.17	30:1	40:1	0.156 in. (4.0 mm)	0.0192
H	0.13	0.11	30:1	40:1	0.156 in. (4.0 mm)	0.0192	
I	0.08	0.07	30:1	40:1	0.156 in. (4.0 mm)	0.0192	
J	0.05	0.04	30:1	40:1	0.156 in. (4.0 mm)	0.0192	

AVAILABLE OPTIONS

- MANUAL HANDWHEEL
- POSITIONERS
- ELECTRIC ACTUATOR
- LIMIT SWITCHES
- FILTERS
- CERTIFICATIONS
- I/P TRANSDUCERS
- REGULATORS

Custom bracketing is available with each option.

Control. Manage. Optimize.

Research Control is a registered trademark of Badger Meter, Inc. Other trademarks appearing in this document are the property of their respective entities. Due to continuous research, product improvements and enhancements, Badger Meter reserves the right to change product or system specifications without notice, except to the extent an outstanding contractual obligation exists. © 2022 Badger Meter, Inc. All rights reserved.

Non-Rotating Manual Actuation

Type NRMA

DESCRIPTION

The Type NRMA Non-Rotating Manual Actuation design is used in applications where either our low-flow trims, cooling fins or bellows are needed and when applications demand human interaction. The manual actuator can be mounted on all RC series valves, including all "P" Trims and all Bonnets. Exchanging between electrical, pneumatic and manual actuators is therefore possible at any time with simple additions. The actuator is encapsulated and completely maintenance-free—designed for fine control.

APPLICATIONS

When you turn the hand wheel, the valve interior moves in a linear motion. This linear movement, from the hand wheel to the internal coupling, prevents damage to the trim and seat, distinguishing this design from conventional manual control valves.

FEATURES

- Hand drive, linear
- Suitable for Badger Meter® modular construction

MATERIALS

Case	1.4404 (316L)
Yoke	1.4404 (316L)
Hand Wheel	Duroplast

SPECIFICATIONS

Weight	Approximately 3.3 lb (1.5 kg)
Temperature	-40...176° F (-40...80° C)
Valve Lift	0.04 in. (1 mm) / 360° turn

SIZES FOR RESEARCH CONTROL VALVES

Sizes	Ø Average	Stroke
1/4 in. standard	0.625 in.	11.1 mm
1/2 in., 3/4 in., 1 in. standard	0.875 in.	14.3 mm
1/2 in., 3/4 in., 1 in. heavy duty guiding	0.875 in.	14.3 mm



DIMENSIONS

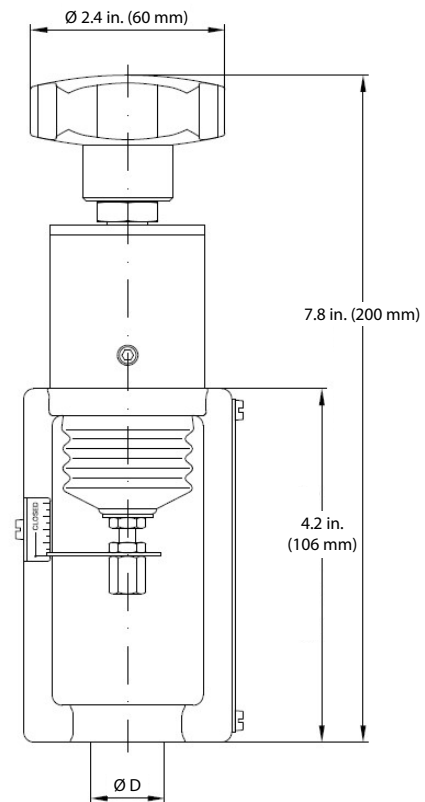

RCV Valves		Trim Sizes Equal %															
% Lift	% Cv	6.0	5	4.5	4	3.5	A	B	C	D	E	F	G	H	I	J	% Lift
0%	0%	0	0	0	0	0	0	0	0	0	0	0	0	0	0	0	0%
5%	1.0%	0.06	0.05	0.04	0.04	0.03	0.02	0.02	0.01	0.008	0.005	0.003	0.002	0.001	0.001	0.000	5%
10%	1.9%	0.11	0.10	0.09	0.08	0.07	0.05	0.04	0.02	0.015	0.010	0.006	0.004	0.002	0.002	0.001	10%
20%	3.8%	0.23	0.19	0.17	0.15	0.13	0.10	0.08	0.05	0.031	0.019	0.012	0.008	0.005	0.003	0.002	20%
25%	4.8%	0.29	0.24	0.22	0.19	0.17	0.12	0.10	0.06	0.038	0.024	0.015	0.010	0.006	0.004	0.002	25%
30%	5.9%	0.35	0.29	0.26	0.23	0.20	0.15	0.12	0.07	0.047	0.029	0.019	0.012	0.008	0.005	0.003	30%
40%	8.8%	0.53	0.44	0.40	0.35	0.31	0.22	0.18	0.11	0.070	0.044	0.028	0.018	0.011	0.007	0.004	40%
50%	13.2%	0.79	0.66	0.59	0.53	0.46	0.33	0.26	0.16	0.105	0.066	0.042	0.026	0.017	0.011	0.007	50%
60%	19.8%	1.19	0.99	0.89	0.79	0.69	0.49	0.40	0.25	0.158	0.099	0.063	0.040	0.026	0.016	0.010	60%
70%	29.6%	1.78	1.48	1.33	1.19	1.04	0.74	0.59	0.37	0.237	0.148	0.095	0.059	0.039	0.024	0.015	70%
75%	36.3%	2.18	1.81	1.63	1.45	1.27	0.91	0.73	0.45	0.290	0.181	0.116	0.073	0.047	0.029	0.018	75%
80%	44.4%	2.67	2.22	2.00	1.78	1.56	1.11	0.89	0.56	0.356	0.222	0.142	0.089	0.058	0.036	0.022	80%
90%	66.7%	4.00	3.33	3.00	2.67	2.33	1.67	1.33	0.83	0.533	0.333	0.213	0.133	0.087	0.053	0.033	90%
100%	100%	6.00	5.00	4.50	4.00	3.50	2.50	2.00	1.25	0.800	0.500	0.320	0.200	0.130	0.080	0.050	100%
Valve Sizes		1"	1"	1"	1", 3/4"	1", 3/4"	1-1/2"	1-1/2"	1-1/2"	1-1/2"	1-1/2"	1-1/4"	1-1/4"	1-1/4"	1-1/4"	1-1/4"	

Trim Sizes O through P-18 are available only in linear characteristic. See Product Data Sheets for maximum Cvs.

RCV Valves		Trim Sizes Equal %															
% Lift	% Cv	6.0	5	4.5	4	3.5	A	B	C	D	E	F	G	H	I	J	% Lift
0%	0%	0	0	0	0	0	0	0	0	0	0	0	0	0	0	0	0%
5%	1.0%	0.30	0.25	0.23	0.20	0.18	0.13	0.10	0.06	0.040	0.025	0.016	0.010	0.007	0.004	0.003	5%
10%	1.9%	0.60	0.50	0.45	0.40	0.35	0.25	0.20	0.13	0.080	0.050	0.032	0.020	0.013	0.008	0.005	10%
20%	3.8%	1.20	1.00	0.90	0.80	0.70	0.50	0.40	0.25	0.160	0.100	0.064	0.040	0.026	0.016	0.010	20%
25%	4.8%	1.50	1.25	1.13	1.00	0.88	0.63	0.50	0.31	0.200	0.125	0.080	0.050	0.033	0.020	0.013	25%
30%	5.9%	1.80	1.50	1.35	1.20	1.05	0.75	0.60	0.38	0.240	0.150	0.096	0.060	0.039	0.024	0.015	30%
40%	8.8%	2.40	2.00	1.80	1.60	1.40	1.00	0.80	0.50	0.320	0.200	0.128	0.080	0.052	0.032	0.020	40%
50%	13.2%	3.00	2.50	2.25	2.00	1.75	1.25	1.00	0.63	0.400	0.250	0.160	0.100	0.065	0.040	0.025	50%
60%	19.8%	3.60	3.00	2.70	2.40	2.10	1.50	1.20	0.75	0.480	0.300	0.192	0.120	0.078	0.048	0.030	60%
70%	29.6%	4.20	3.50	3.15	2.80	2.45	1.75	1.40	0.88	0.560	0.350	0.224	0.140	0.091	0.056	0.035	70%
75%	36.3%	4.50	3.75	3.38	3.00	2.63	1.88	1.50	0.94	0.600	0.375	0.240	0.150	0.098	0.060	0.038	75%
80%	44.4%	4.80	4.00	3.60	3.20	2.80	2.00	1.60	1.00	0.640	0.400	0.256	0.160	0.104	0.064	0.040	80%
90%	66.7%	5.40	4.50	4.05	3.60	3.15	2.25	1.80	1.13	0.720	0.450	0.288	0.180	0.117	0.072	0.045	90%
100%	100%	6.00	5.00	4.50	4.00	3.50	2.50	2.00	1.25	0.800	0.500	0.320	0.200	0.130	0.080	0.050	100%
Valve Sizes		1"	1"	1"	1", 3/4"	1", 3/4"	1-1/2"	1-1/2"	1-1/2"	1-1/2"	1-1/2"	1-1/4"	1-1/4"	1-1/4"	1-1/4"	1-1/4"	

Numbers are for reference or comparison only.

% Lift	% Maximum Cv	
	Linear	Equal %
0%	0%	0%
5%	5%	1%
10%	10%	2%
20%	20%	4%
25%	25%	5%
30%	30%	6%
40%	40%	9%
50%	50%	13%
60%	60%	20%
70%	70%	30%
75%	75%	36%
80%	80%	44%
90%	90%	67%
100%	100%	100%

