

Hy-Lok RV Series

Relief Valves

Catalog No. H-RV100
Feb. 2018

**RV 1
Series**

Low Pressure Relief Valve

High Pressure Relief Valve

**RV 2
Series**

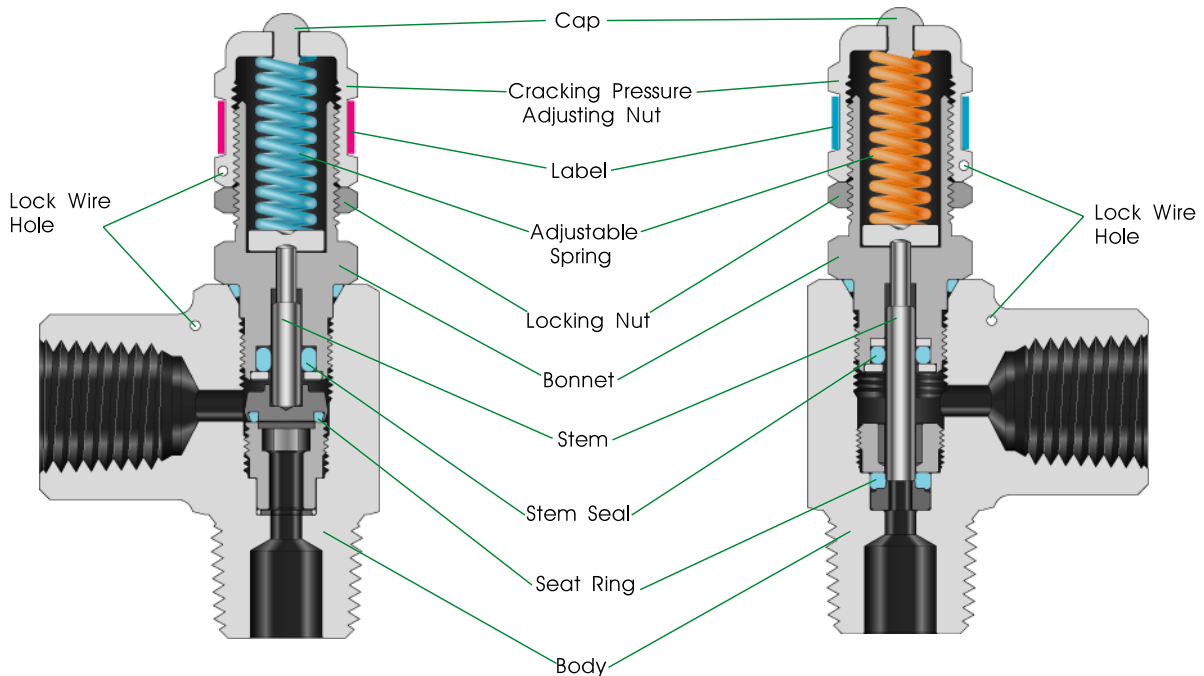

Technical Data

- | | |
|--|---|
| <ul style="list-style-type: none"> • Cracking Pressure Range : 10~255psig to atmosphere • Max.Working Pressure : 300psig • Operating Temperature Range : -10°F~400°F(-23°C~204°C) • Orifice Size : 4.8mm (0.19in) • One Spring adjustable over entire cracking pressure range, blue-color spring standard • Cracking Pressure is affected by the outlet pressure | <ul style="list-style-type: none"> • Cracking Pressure Range : 50~6000psig to atmosphere • Max.Working Pressure : 6000psig • Operating Temperature Range : -10°F~400°F(-23°C~204°C) • Orifice Size : 4.8mm (0.19in) • Various Springs are available as below mentioned. • Cracking Pressure is not affected by the outlet pressure. |
|--|---|

Features

- **Compact body** for installation in small space
- **Cracking pressure** adjustable externally
- **Lock wire capability** to maintain pressure relief setting
- **100% factory tested** crack and reseat performance

Materials of Construction

- Body Material : Stainless Steel 316 (standard)
- Seal : Viton (standard)
- Spring : SS631 (standard)
- Cap : Polypropylene (standard)

Valve Operation and Adjusting Cracking pressure

To increase the cracking pressure, turn the cracking pressure adjusting nut clockwise making the spring more compressed.

RV2 Series Spring and Cracking Pressure

| Spring Designator | Cracking Pressure | | | |
|-------------------|-------------------|-------------|---------------|--------|
| | psig | bar | kPa | Color |
| S | 50 - 350 | 3.4 - 24.1 | 340 - 2410 | Blue |
| A | 225 - 750 | 15.5 - 51.5 | 1550 - 5150 | Yellow |
| B | 750 - 1500 | 51.5 - 103 | 5150 - 10300 | Purple |
| C | 1500 - 2250 | 103 - 155 | 10300 - 15500 | Orange |
| D | 2250 - 3000 | 155 - 206 | 15500 - 20600 | Brown |
| E | 3000 - 4000 | 206 - 275 | 20600 - 27500 | White |
| F | 4000 - 5000 | 275 - 344 | 27500 - 34400 | Red |
| G | 5000 - 6000 | 344 - 414 | 34400 - 41400 | Green |

HY-LOK CORPORATION

©1998-2018 HY-LOK CORPORATION All rights reserved



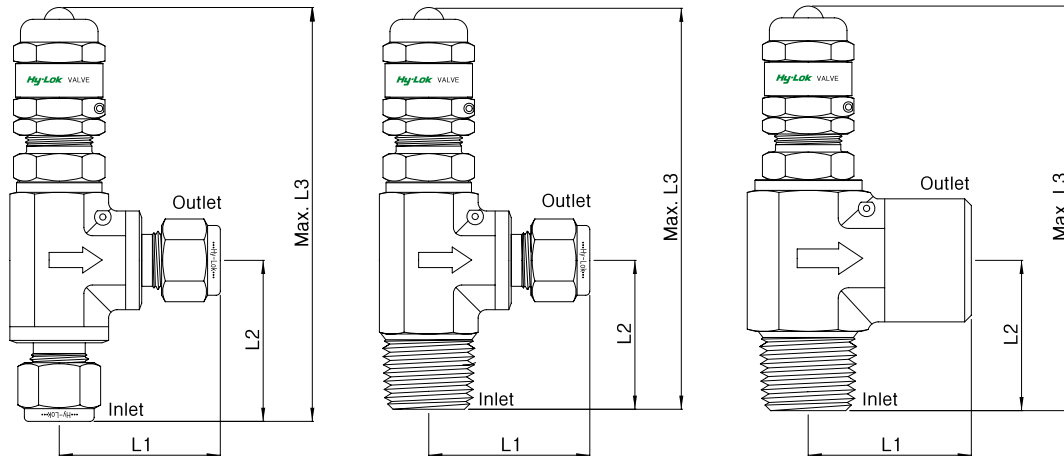

Table of Dimensions

| Basic Part No. | | | Orifice | End Connections | | Dimensions | | |
|------------------|----|---------|---------|-----------------|-----------------|------------|------|-------|
| | | | | Inlet | Outlet | L1 | L2 | L3 |
| RV1 or RV2 | H | -4 T- | 4.8 | 1/4" Hy-Lok | 1/4" Hy-Lok | 38.7 | 37.3 | 104.6 |
| | H | -6M- | | 6mm Hy-Lok | 6mm Hy-Lok | | | |
| | H | -8M- | | 8mm Hy-Lok | 8mm Hy-Lok | | | |
| | H | -8 T- | | 1/2" Hy-Lok | 1/2" Hy-Lok | 46.7 | 46.7 | 114.0 |
| | H | -12M- | | 12mm Hy-Lok | 12mm Hy-Lok | | | |
| | MH | -8N8T- | | 1/2" Male NPT | 1/2" Hy-Lok | | | |
| | MH | -8N12M- | | 1/2" Male NPT | 12mm Hy-Lok | 30.0 | 32.2 | 99.5 |
| | MF | -4N- | | 1/4" Male NPT | 1/4" Female NPT | | | |
| | MF | -6N- | | 3/8" Male NPT | 3/8" Female NPT | | | |
| | MF | -8N- | | 1/2" Male NPT | 1/2" Female NPT | 38.0 | 35.7 | 103.0 |

All dimensions are in millimeters.

Ordering Information

RV2

Series Designator

- RV1 : Low Pressure
- RV2 : High Pressure

MH

End Connection Designator

- H : Both End Hy-Lok Tube Fitting
- MH: Male Pipe Thread & Hy-Lok Tube Fitting
- MF : Male Pipe Thread & Female Pipe Thread

8N

Size Designator

Inlet Outlet

8T

B

Spring / Cracking Pressure Designator*

- S : 50 - 350 psig
- A : 225 - 750 psig
- B : 750 - 1500 psig
- C : 1500 - 2250 psig
- D : 2250 - 3000 psig
- E : 3000 - 4000 psig
- F : 4000 - 5000 psig
- G : 5000 - 6000 psig

S316

Body Material Designator

- S316 : 316 Stainless Steel

• NPT (ISO/BSP)

| Thread(in.) | 1/4 | 3/8 | 1/2 |
|-------------|-------|-------|-------|
| Designator | 4N(R) | 6N(R) | 8N(R) |

• Tube

| Fractional Tube | O.D.(in.) | 1/4 | 3/8 | 1/2 |
|-----------------|-----------|-----|-----|-----|
| Designator | | 4T | 6T | 8T |
| Metric Tube | O.D.(mm) | 6 | 8 | 12 |
| Designator | | 6M | 8M | 12M |

Note* : No spring / cracking pressure designator is required for RV1 low pressure series valves.

SAFETY in VALVE SELECTION

Proper installation, materials compatibility, operation and maintenance of these valves are the responsibility of the user. The total system design must be taken into consideration to ensure optimal performance and safety.