

Specifications

For other materials or modifications, please consult TESCO. M.

OPERATING PARAMETERS

Pressure rating per criteria of ANSI/ASME B31.3

Maximum Inlet Pressure

600 psig / 41.4 bar

Outlet Pressure Ranges

30, 60, 100, 150 psig

2.1, 4.1, 6.9, 10.3 bar

Design Proof Pressure

150% maximum rated

Inboard Leak Rate

$< 2 \times 10^{-8}$ atm cc/sec He

Operating Temperature

PCTFE Seat

-40°F to 140°F / -40°C to 60°C

Teflon® PFA Seat

-40°F to 160°F / -40°C to 71°C

Flow Capacity

$C_V = 1.0$

MEDIA CONTACT MATERIALS

Body

316L Stainless Steel with Electropolish

Diaphragm

Nickel Alloy (Hastelloy®)

Valve Seat

PCTFE or PTFE PFA

Seat Retainer

Nitronic 60 Stainless Steel

Stem, Seal, and Remaining Parts

316 Stainless Steel

OTHER

Internal Surface Finish

25 R_a microinch / 0.63 micrometer

Connections

Welded female or male VCR®

Tube stubs

Compression fittings

High Purity Internal Connections (H.P.I.C.) (gauge port only)

Cleaning

DI water electronic grade cleaned

Weight (without gauges)

3.5 lbs / 1.6 kg

Teflon® is a registered trademark of E.I. du Pont de Nemours and Company.

VCR® is a registered trademark of Cajon Co.

Hastelloy® is a registered trademark of Haynes International, Inc.



TESCOM 22-5400 Series high purity, high flow BA Grade pressure reducing regulator offers a $C_V = 1.0$ and a 316 Stainless Steel Electropolished body of 25 R_a . Inlet pressure is 600 psig / 41.4 bar with outlet pressures up to 150 psig / 10.3 bar.

Applications

- High flow purging
- Regulating corrosive and specialty gases
- Bulk gas delivery

Features and Benefits

- Compact, hand-loaded and pressure reducing
- Low internal volume
- Metal-to-metal diaphragm to body seal for high leak integrity
- 1.3 C_V is available - consult TESCO. M.

NOTE:

When choosing a regulator and control pressure, decaying inlet characteristic must be considered when the supply pressure is expected to change. The decaying inlet characteristic of a pressure reducing regulator is commonly known as the increase in control pressure due to the decrease in supply pressure. It is important to make sure this effect does not cause the control pressure to exceed the pressure rating of the unit's outlet or that of the downstream system.

For more information on decaying inlet, please refer to the Technical Information section of the product catalog and/or contact the TESCO. M. customer support further assistance.

22-5400 SERIES

22-5400 Series Regulator Drawing

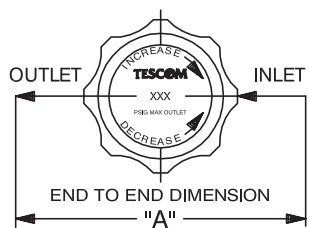

Figure A (no gauges)

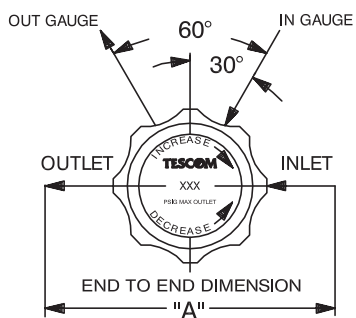

Figure B (2 gauges)

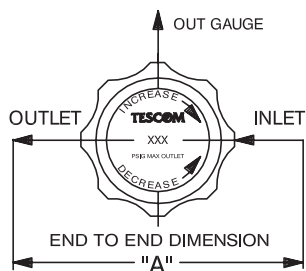
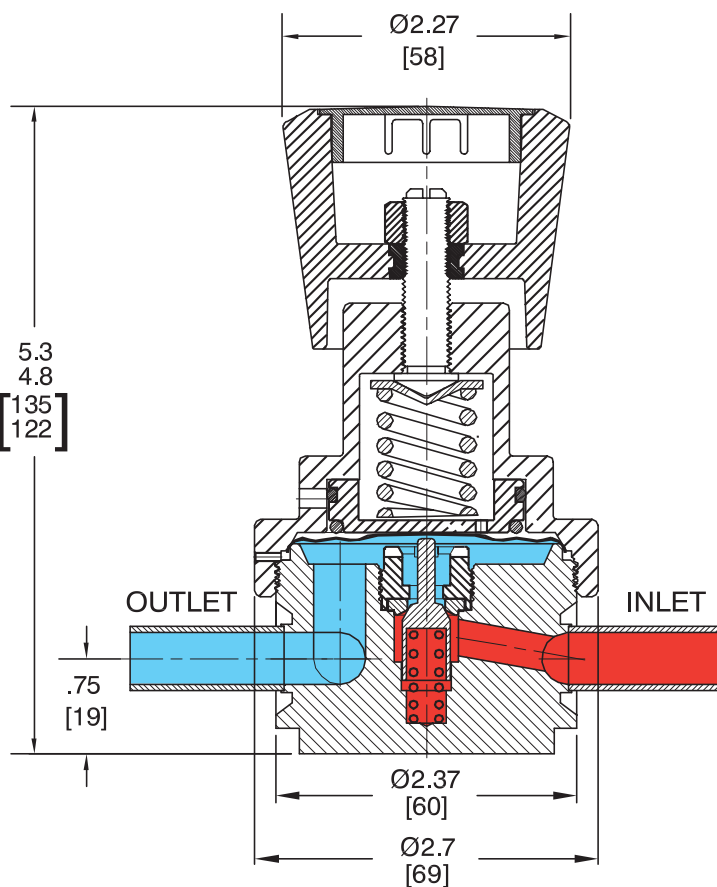
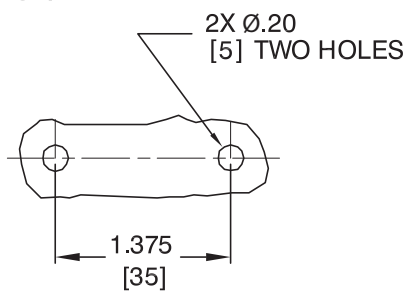

Figure C (1 gauge)



M5 X .30 DEPTH (2X)
(WILL ACCEPT
10-32 SCREW)



PANEL CUT OUT

All dimensions are reference & nominal
Metric [millimeter] equivalents are in brackets

22-5400 Series Regulator Flow Charts

For more information on how to read flow curves, please refer to the Flow Curves and Calculations document (debul2007x012) in the TESCOM catalog or on www.tescom.com.

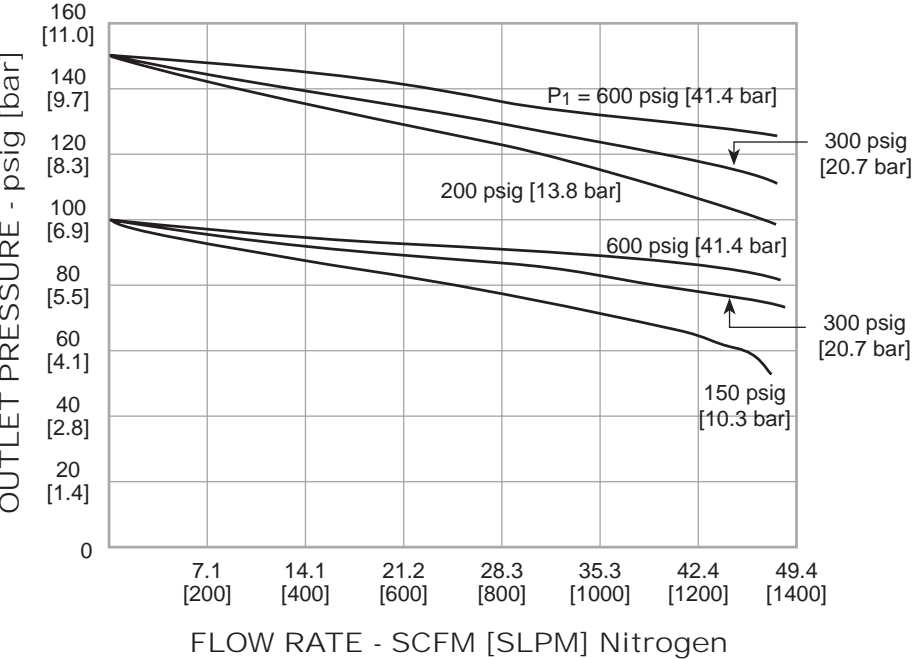
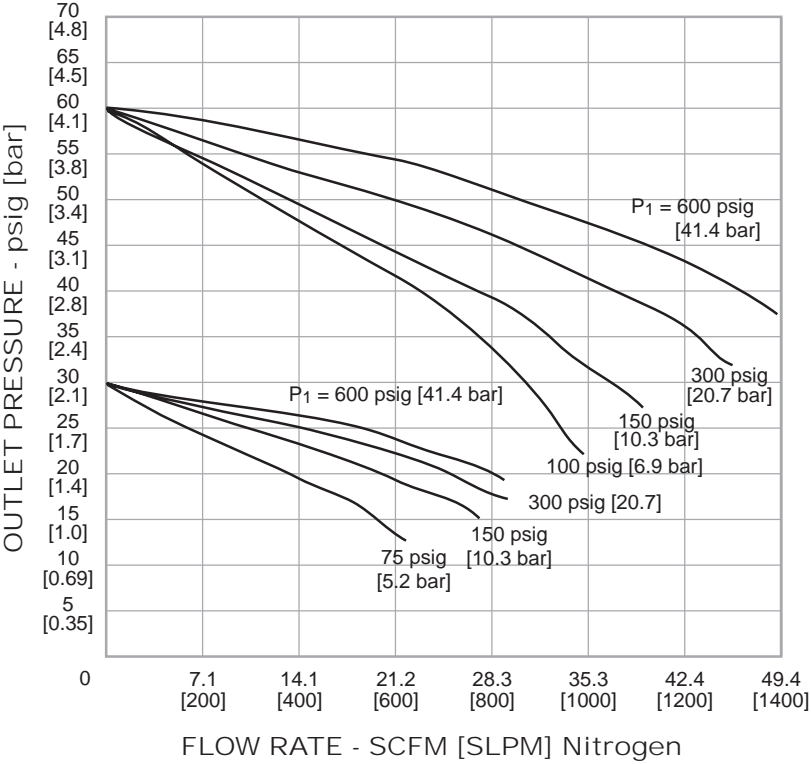

22-5400 SERIES

22-5400 Series Regulator Part Number Selector

Repair Kits, Accessories & Modifications may be available for this product. Please contact TESCOM for more information.

Example for selecting a part number:

22-54 4 2 K RW 1 1

BASIC SERIES	BODY MATERIAL	FINISH	OUTLET PRESSURE	SEAT MATERIAL	INLET AND OUTLET PORT TYPE AND SIZE	'A' ± .06"	MAXIMUM INLET PRESSURE	GAUGE PORT OPTION	NUMBER OF GAUGE PORTS (FIGURE)
22-54	4 – 316 Stainless Steel Electropolish	25 R _a	0 – 30 psig 2.1 bar	K – PCTFE	T6 – 3/8" O.D. Tube	3.70	1 – 600 psig 41.4 bar	0 – None	0 (A)
			1 – 60 psig 4.1 bar	T – PTFE PFA	T8 – 1/2" O.D. Tube	3.70		1 – 1/4" H.P.I.C.	1 (C)
			2 – 100 psig 6.9 bar		RU – 1/2" Male Swivel	5.59		2 – 1/4" H.P.I.C.	2 (B)
			3 – 150 psig 10.3 bar		RW – 1/2" Female Swivel	5.59			
					C6 – 3/8" Compression Fitting	6.42			
					C8 – 1/2" Compression Fitting	6.00			