

Specifications

For other materials or modifications, please consult TESCOM.

OPERATING PARAMETERS

Pressure rating per criteria of ANSI/ASME B31.3

Maximum Inlet Pressure

600, 1000, 3500 psig / 41.4, 69.0, 241 bar

Outlet Pressure Ranges

30, 60, 100, 150 psig / 2.1, 4.1, 6.9, 10.3 bar

Design Proof Pressure

150% of maximum rated

Inboard Leak Rate

$< 1 \times 10^{-9}$ atm cc/sec He, per ASTM E449

Operating Temperature

Vespel®: -40°F to 350°F / -40°C to 177°C

PCTFE: -40°F to 140°F / -40°C to 60°C

Teflon® PFA: -40°F to 160°F / -40°C to 71°C

Flow Capacity

$C_v = 0.5$



MEDIA CONTACT MATERIALS

Body

316L VAR Stainless Steel with Electropolish

Diaphragm

316 Stainless Steel or Nickel Alloy (Hastelloy®)

Valve Seat

Polyimide (Vespel®) (3500 psig / 241 bar Inlet)

PCTFE (600, 100 psig / 41.4, 6.9 bar Inlet)

PTFE PFA (600 psig / 41.4 bar Inlet)

Remaining Parts

316 Stainless Steel

OTHER

Internal Surface Finish

10 R_a microinch / 0.25 micrometer

Connections

Welded female or male VCR®

Tube stubs

Compression

High Purity Internal Connections (H.P.I.C.)

(Internal style of VCR®, compatible with male swivel VCR®)

Internal Volume

15 cc

Weight (without gauges)

3.2 lbs / 1.5 kg

Teflon® and Vespel® are registered trademarks of E.I. du Pont de Nemours and Company.

VCR® is a registered trademark of Cajon Co.

Hastelloy® is a registered trademark of Haynes International, Inc.

NOTE:

When choosing a regulator and control pressure, decaying inlet characteristic must be considered when the supply pressure is expected to change. The decaying inlet characteristic of a pressure reducing regulator is commonly known as the increase in control pressure due to the decrease in supply pressure. It is important to make sure this effect does not cause the control pressure to exceed the pressure rating of the unit's outlet or that of the downstream system.

For more information on decaying inlet, please refer to the Technical Information section of the product catalog and/or contact the TESCOM customer support further assistance.

TESCOM 74-3800 Series ultra high purity, tied diaphragm pressure reducing regulator offers high flow and internally threadless and low internal volume design with $C_v = 0.5$. The 74-3800 Series is available with 10 R_a surface finish. Inlet pressures are 600, 1000, or 3500 psig / 41.3, 69, 241 bar with outlet pressures up to 150 psig / 10.3 bar.

Applications

- 1/2" point-of-use pressure regulator
- Gas cabinets
- High flow purging systems
- Semiconductor manufacturing

Features and Benefits

- Internally springless and threadless design
- Metal-to-metal diaphragm to body seal for high leak integrity
- Smooth unobstructed flow path allows for complete purging
- Positive shut-off seal, tied diaphragm design with positionable captured vent bonnet
- Hastelloy® trim option is available

74-3800 SERIES

74-3800 Series Regulator Drawing

FIGURE A (NO GAUGE)

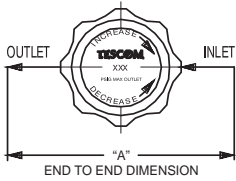

FIGURE B (2 GAUGES)

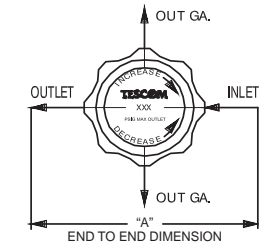
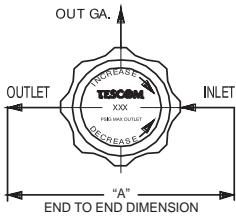
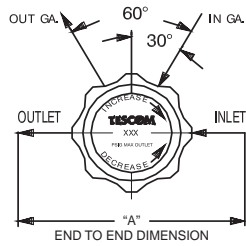
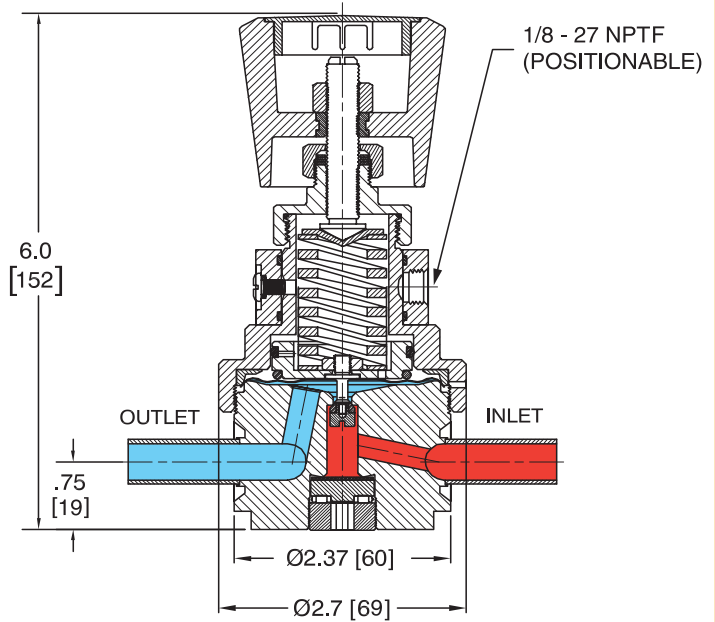
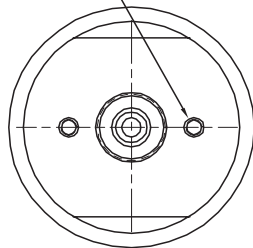

FIGURE C (1 GAUGE)

FIGURE D (2 OUTLET GAUGES)



M5 X .30 DEPTH (2X)
ACCEPTS #10-32
UNF SCREW



2X .20 DIA. [5]
TWO HOLES

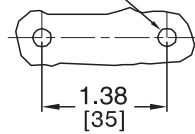

PANEL CUT OUT

All dimensions are reference & nominal
Metric [millimeter] equivalents are in brackets

74-3800 Series Regulator Flow Chart

For more information on how to read flow curves, please refer to the Flow Curves and Calculations document (debul2007x012) in the TESCOM catalog or on www.tescom.com.

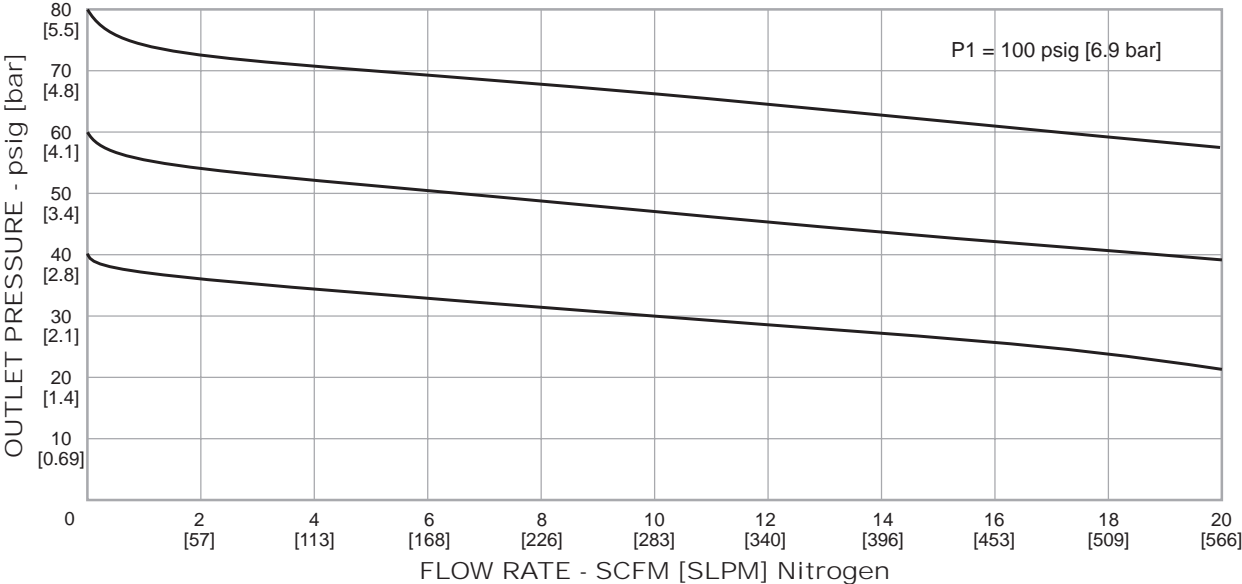

74-3800 SERIES

74-3800 Series Regulator Part Number Selector

Repair Kits, Accessories & Modifications may be available for this product. Please contact TESCOM for more information.

Example for selecting a part number:

| 74-38 | 6 | 2 | K | RW | 1 | 0 | | | |
|--------------|--------------------------------------------------|--------------------------------|---------------------------------------------------------------------------------------------------------|------------------------------------------------------------------------------------------------------------------------------------------------------------------------------------|----------------------------------------------------------------------------------------------------------------------------------------------------|----------------------------------------------|-------------------------------------------------------------------------------------------------------------------------------------------------------------------------------------------------------|-------------------------------------------------------------------------------------------------------------------------------------------------------------------------------------------------------------------------------|----------------------------------------------------------------------------------------------------------------------------------------------------------------------------------------------|
| BASIC SERIES | BODY MATERIAL | FINISH | OUTLET PRESSURE | SEAT MATERIAL | INLET AND OUTLET PORT SIZE AND TYPE | 'A' ± .06" | INLET PRESSURE | GAUGE PORT OPTIONS | NUMBER OF GAUGE PORTS (FIGURE) |
| 74-38 | 6 – 316L VAR Stainless Steel Electropolish | 10 R _a ¹ | 0 – 30 psig 2.1 bar 1 – 60 psig 4.1 bar 2 – 100 psig 6.9 bar 3 – 150 psig 10.3 bar | V – Polyimide (Vespel®) (3500 psig / 241 bar only) K – PCTFE (600 and 1000 psig / 41.4 and 69.0 bar only) T – PTFE PFA (600 psig / 41.4 bar only) | C6 – 3/8" Compression C8 – 1/2" Compression RU – 1/2" Male Swivel RW – 1/2" Female Swivel T6 – 3/8" Tube Stubs T8 – 1/2" Tube Stubs | 6.42 6.00 5.59 5.59 3.70 3.70 | SST Trim 1 – 3500 psig 241 bar 2 – 1000 psig 69.0 bar 3 – 600 psig 41.4 bar Hastelloy® Trim 4 – 1000 psig 69.0 bar 5 – 3500 psig 241 bar 6 – 600 psig 41.4 bar | 0 – None 1 – 1/4" H.P.I.C. 2 – 1/4" H.P.I.C. 3 – 1/4" H.P.I.C. 4 – 1/4" Male Swivel 5 – 1/4" Male Swivel 6 – 1/4" Male Swivel 7 – 1/4" Female Swivel 8 – 1/4" Female Swivel 9 – 1/4" Female Swivel | 0 (Figure A) 1 (Figure C) 2 (Figure B) 2 (Figure D) 2 (Figure D) 1 (Figure C) 2 (Figure B) 2 (Figure D) 1 (Figure C) 2 (Figure B) 2 (Figure D) 1 (Figure C) |

1. Per SEMI F19, HP grade

Specifications

For other materials or modifications, please consult TESCOM.

OPERATING PARAMETERS

Pressure rating per criteria of ANSI/ASME B31.3

Maximum Inlet Pressure

300 psig / 20.7 bar

Outlet Pressure Ranges

0-20, 0-50, 0-100, 0-150, 0-250 psig
0-1.4, 0-3.4, 0-6.9, 0-10.3, 0-17.2 bar

Design Proof Pressure

150% of rated pressure

Leakage

Bubble-tight

Operating Temperature

-20°F to 300°F / -28°C to 148°C

Flow Capacity

1/2" Port Size: $C_v = 2.5$

3/4" Port Size: $C_v = 3.5$

1 and 1-1/2" Port Size: $C_v = 5.0$

MEDIA CONTACT MATERIALS

Body

316L Stainless Steel

Diaphragm

PTFE

Seat, Valve

Ethylene Propylene

O-Rings

Ethylene Propylene

Valve Spring

Cobalt Chrome Nickel Alloy (Elgiloy®)

Remaining Parts

316 Stainless Steel

OTHER

Internal Surface Finish

20 R_a , 30 R_a microinch / 0.63, 0.80 micrometer

Connections

Sanitary Fittings

Tube Ends

High Purity Internal Connections (H.P.I.C.) (gauge port only)

Cleaning

CGA 4.1 and ASTM G93 Clean Service Certificate of Conformance available

Weight

16 lbs / 7 kg

VCR® is a registered trademark of Cajon Co.

Gylon® is a registered trademark of Garlock, Inc.

Elgiloy® is a registered trademark of Elgiloy Specialty Metals.



TESCOM PH-1600 Series is part of our Pharmpure™ product line. This high purity, high flow single-stage regulator offers a compact, USP Class VI and BPE compliant design suitable for biotech and pharmaceutical applications. This regulator provides gas flows up to 400 SCFM / 11,320 SLPM. Its Gylon® diaphragm ensures gas purity and integrity.

Applications

- Clean steam for sanitization
- Vessel headspace pressurization

Features and Benefits

- Up to $C_v = 5.0$ flow capacity
- Gylon® diaphragm
- Low droop, high flow
- Five outlet pressure ranges
- Accurately regulates pressures up to 250 psig / 17.2 bar
- Welded sanitary connections and tube ends are available
- Soft goods USP Class VI compliant
- BPE 2009 compliant design