

Specifications

For other materials or modifications, please consult TESCO M.

OPERATING PARAMETERS

Pressure rating per criteria of ANSI/ASME B31.3

Maximum Inlet Pressure

150 psig / 10.3 bar

Outlet Pressure Ranges

Spring (handknob)

0-10, 0-25, 0-50, 0-100, and 0-150 psig
0-0.69, 0-1.7, 0-3.4, 0-6.9, and 0-10.3 bar

Spring Bias and Dome

0-100 psi / 0-6.9 bar (See Part Number Selector for more details)

Design Proof Pressure

150% maximum rated

Leakage

Internal: Bubble-tight

External: designed to meet $< 2 \times 10^{-8}$ atm cc/sec He

Operating Temperature (media only)

Teflon® Seat: -40°F to 165°F / -40°C to 74°C

PEEK-OPTIMA® or PEEK-Classix® Seat: -40°F to 400°F / -40°C to 204°C

Flow Capacity

$C_v = 0.02, 0.06, 0.15, \text{ and } 0.24$

MEDIA CONTACT MATERIALS

Body

316L Stainless Steel

Seat

PTFE or PEEK-OPTIMA®, PEEK-Classix®

Friction Sleeve

Inner: PTFE

Outer: 316 Stainless Steel

Valve Guide

316 Stainless Steel

Diaphragm

316 Stainless Steel

Seat Retainer

Nitronic 60

Remaining Parts

316 Stainless Steel

OTHER

Connections

Sanitary Fittings

Tube Ends

High Purity Internal Connections (H.P.I.C.) (gauge port only)

Cleaning

CGA 4.1 and ASTM G93, Clean Service Certificate of Conformance available

Weight (approximately)

2.0 lbs / 0.9 kg

Teflon® is a registered trademark of E.I. du Pont de Nemours and Company.

PEEK-OPTIMA® is a registered trademark of Invibio Ltd.

PEEK-Classix® is a registered trademark of Invibio Ltd.



TESCOM PH-2600 Series is part of our Pharmpure™ product line. This high purity single-stage regulator offers a compact, USP Class VI and BPE compliant design suitable for specialty, corrosive, and pyrophoric applications. This regulator offers gas flows of < 10 SCFM / 283 SLPM. Diffusion-resistant metal diaphragm seal ensures gas purity and integrity.

Applications

- Sparge gases
- Clean steam for sanitization
- Transfer panels
- Low flow specialty gas

Features and Benefits

- 316L Stainless Steel barstock regulator body design
- FDA/USP compliant designs are available
- Clean Service Certification of Compliance available: Includes actual material certification, weld records, and bill of materials
- 15 or 32 R_a microinch / 0.38 or 0.81 micrometer body surface finishes are available
- Precise pressure control
- Gauge port is available
- ASME BPE 2009 compliant design

PH-2600 SERIES

PH-2600 Series Regulator Drawing

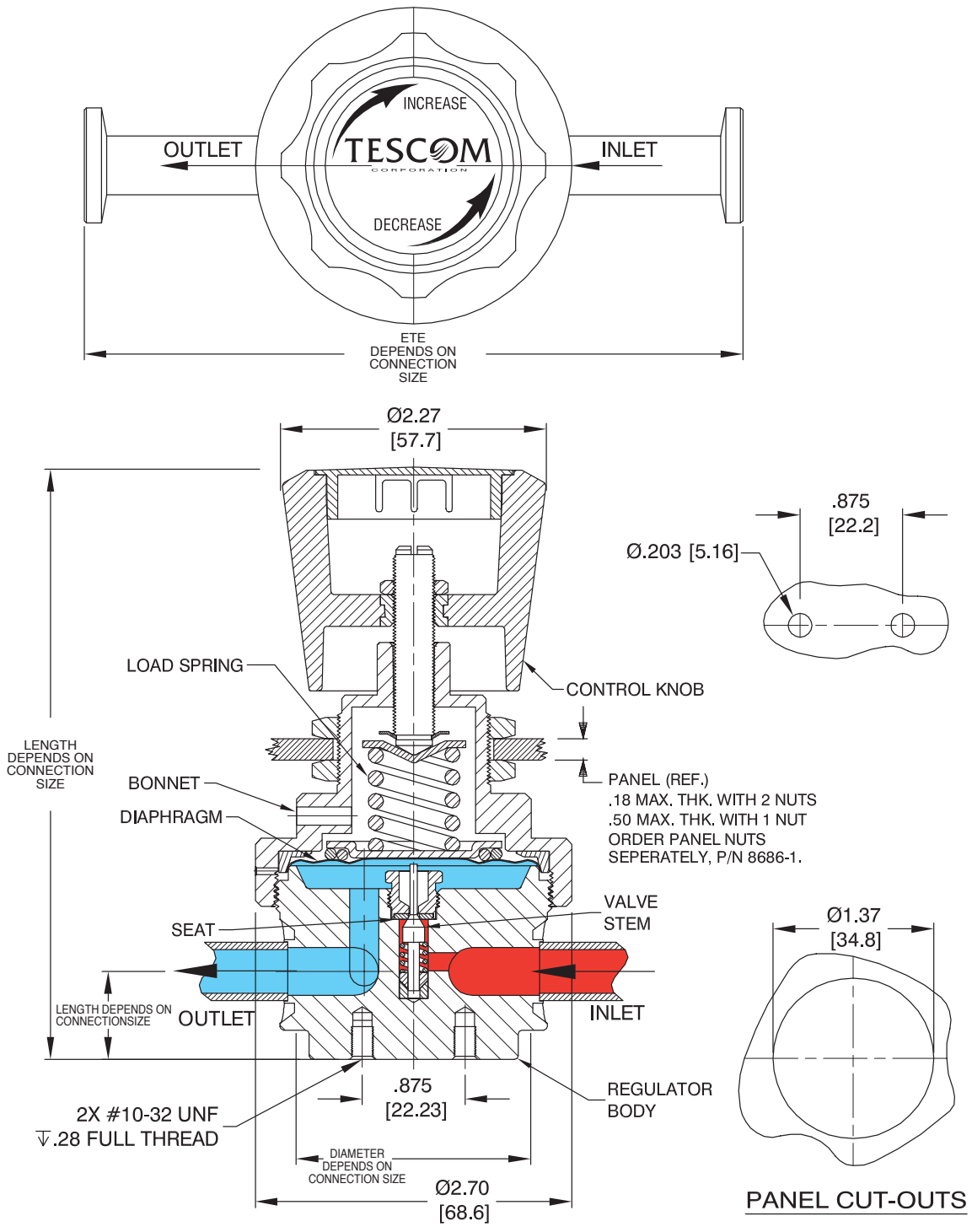

All dimensions are reference & nominal
Metric [millimeter] equivalents are in brackets

PH-2600 Series Regulator Flow Charts

For more information on how to read flow curves, please refer to the Flow Curves and Calculations document (debul2007x012) in the TESCOM catalog or on www.tescom.com.

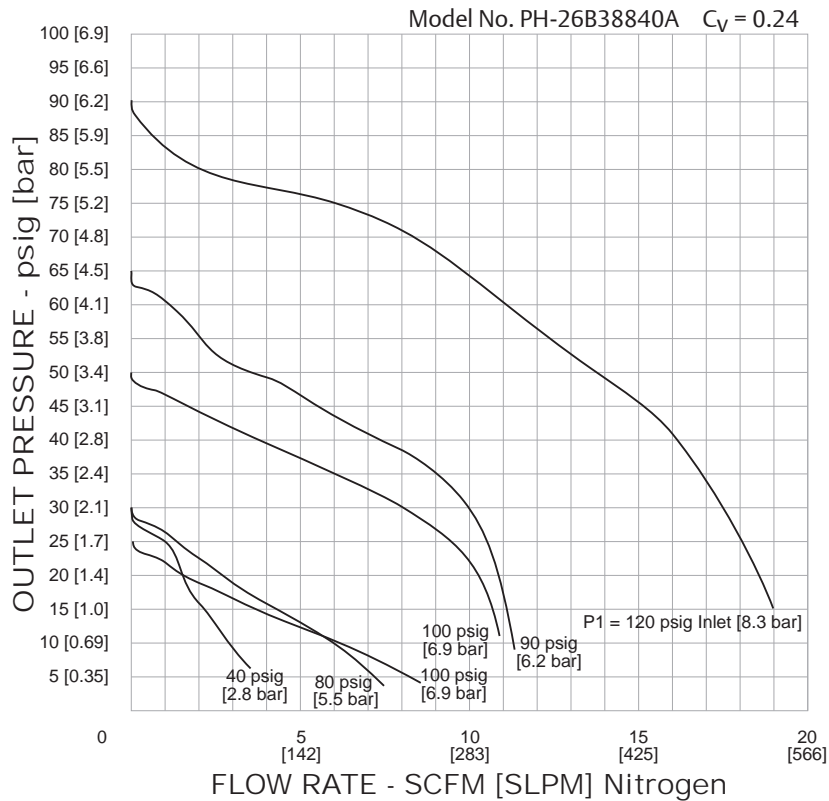
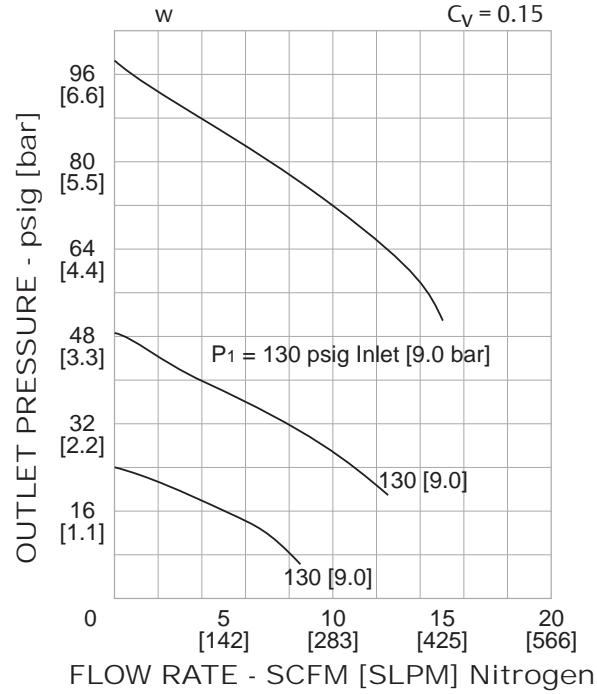

PH-2600 SERIES

PH-2600 Series Regulator Part Number Selector

Repair Kits, Accessories & Modifications may be available for this product. Please contact TESCOM for more information.

Example for selecting a part number:

PH-26	A				1	8	8	2	0	B	
BASIC SERIES	BODY MATERIAL	BODY SURFACE FINISH	SEAT MATERIAL	VALVE SPRING	LOAD TYPE	OUTLET PRESSURE	INLET AND OUTLET PORT TYPE	INLET AND OUTLET PORT SIZE WALL THICKNESS	FLOW CAPACITY	GAUGE PORT OPTIONS	CERTIFICATE OF CONFORMANCE
PH-26	A – 316L Stainless Steel	15 R _a	PTFE	316 Stainless Steel	0 – Spring 1 – Spring	0-10 psig / 0-0.69 bar 0-25 psig / 0-1.7 bar	8 – Sanitary 9 – Tube	6 – 3/8" (Tube Only) 0.375" OD x 0.035" wall 8 – 1/2" 0.500" OD x 0.065" wall	0 – C _v = 0.02 1 – C _v = 0.06 2 – C _v = 0.15 4 – C _v = 0.24	0 – No gauge ports 2 – One 1/4" HPIC outlet gauge port at 90°	A – None B – Clean Service Certification
	B – 316L Stainless Steel	15 R _a	PTFE	Cobalt Chrome Nickel Alloy (Eligiloy®)	2 – Spring 3 – Spring	0-50 psig / 0-3.4 bar 0-100 psig / 0-6.9 bar					
	C – 316L Stainless Steel	32 R _a	PTFE	316 Stainless Steel	4 – Spring Bias Pressure	0-50 psig / 0-3.4 bar Spring Bias Pressure					
	D – 316L Stainless Steel	32 R _a	PEEK	Cobalt Chrome Nickel Alloy (Eligiloy®)	5 – Spring Bias Pressure 6 – Dome	0-100 psig / 0-6.9 bar 0-100 psig / 0-6.9 bar					